

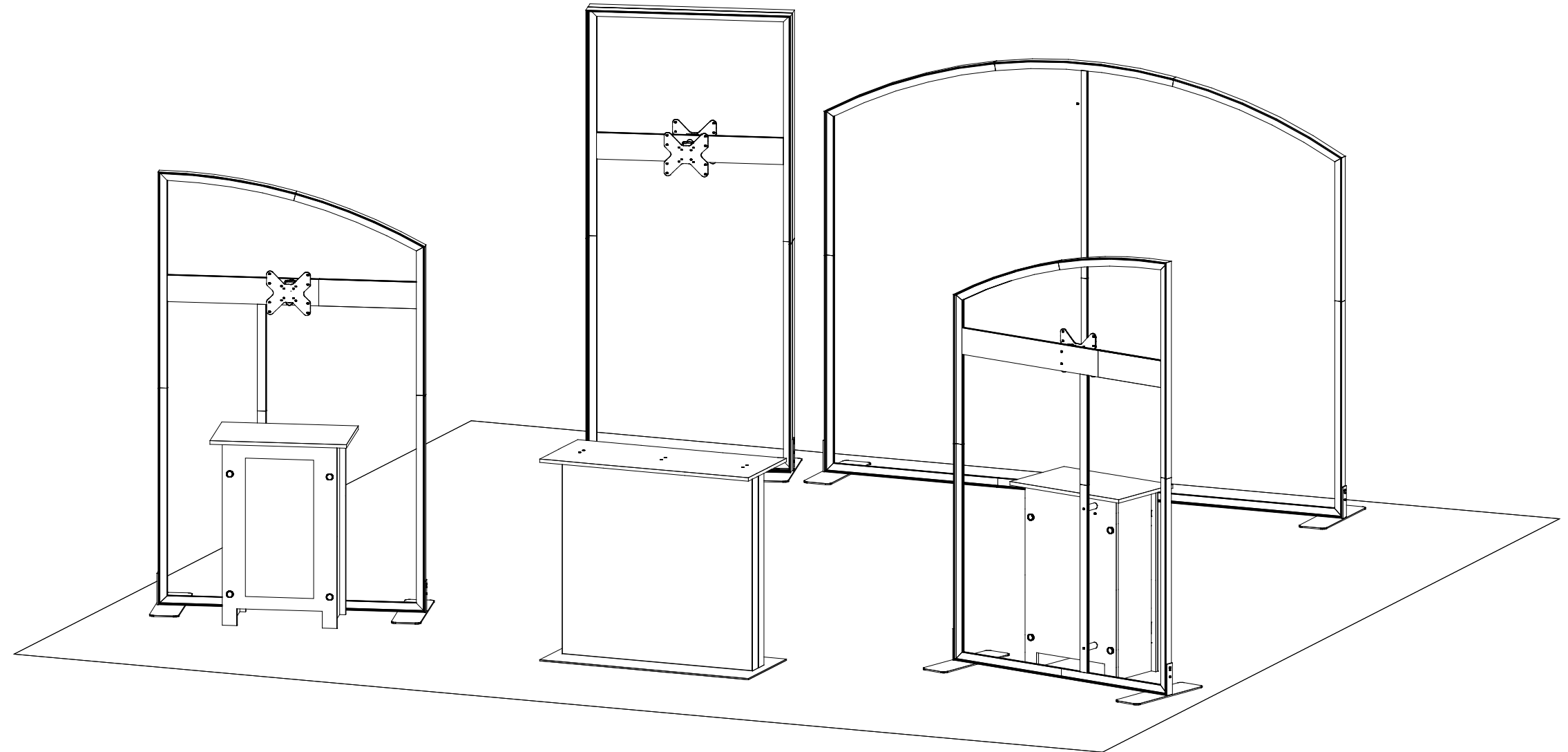

Plan View

20'

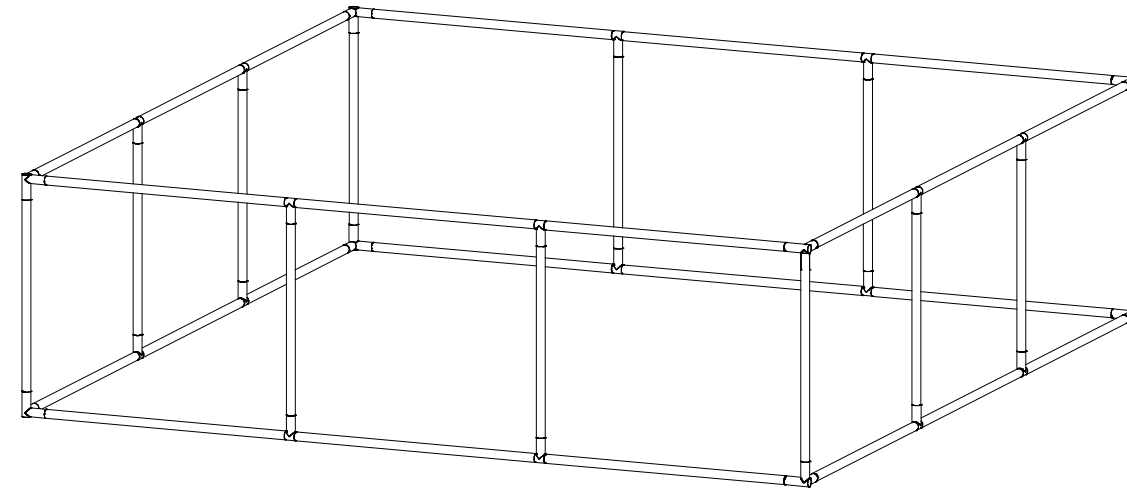
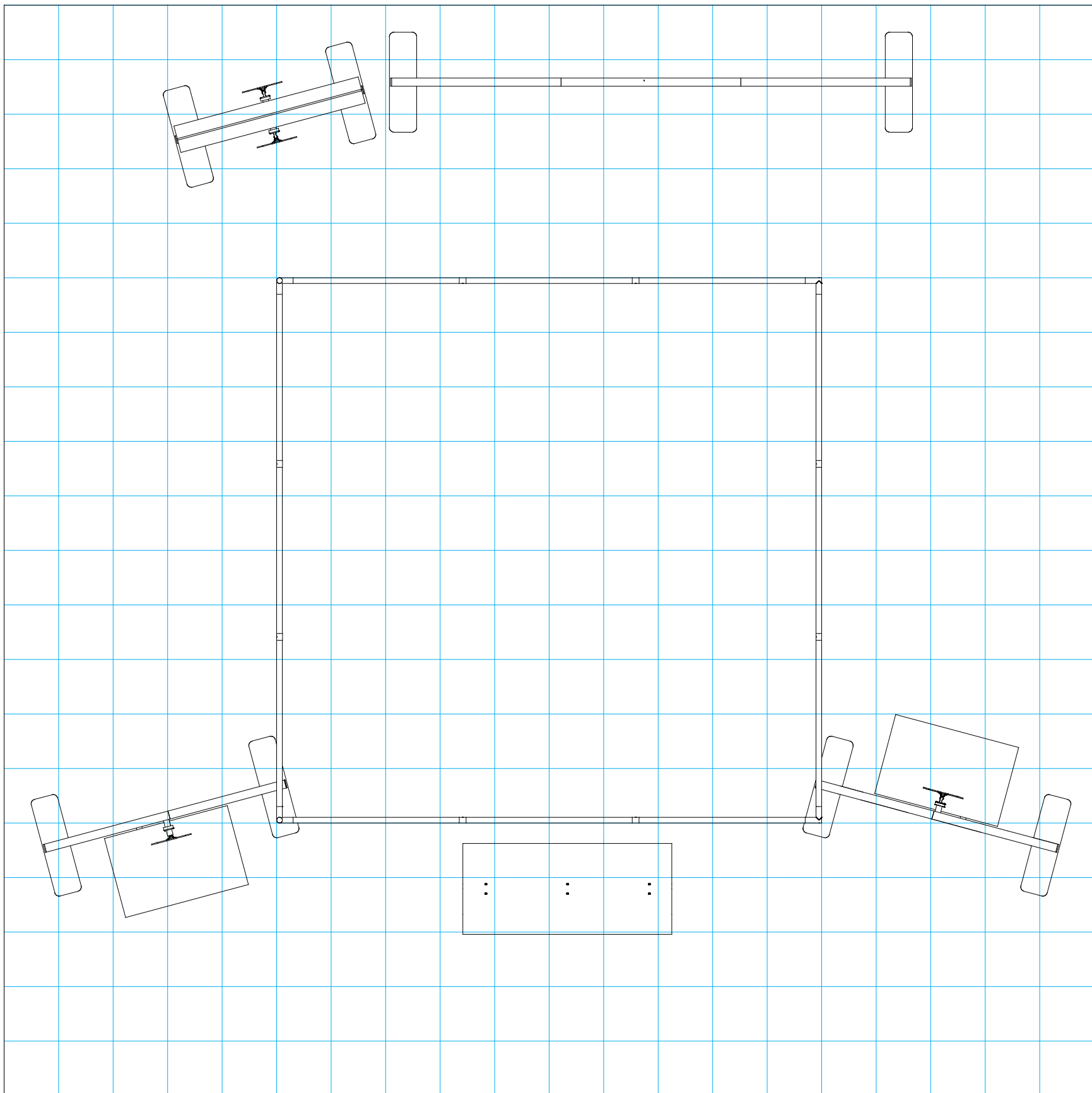

SETUP INSTRUCTIONS



 = 1 sq foot

General Setup Instructions

- Read entire setup instruction manual prior to unpacking parts and pieces.
- The setup instructions are created specifically for this configuration.
- Setup instructions are laid out sequentially in steps, including exploded views with detailed explanation for assembly.

Cleaning & Packing

- For Cleaning Metal, Plex, & Laminate Parts: Use a **MILD NON-ABRASIVE** cleanser and soft cloth/paper towel to clean all surfaces.
- Keep exhibit components away from heat and prolonged sun exposure. **Heat and UV exposure will warp and fade components.**
- Retain all provided Packing Materials. All provided packing materials are for ease of repacking & component protection.

Disassembly

- For loss prevention, tighten all set screws and locks during disassembly.

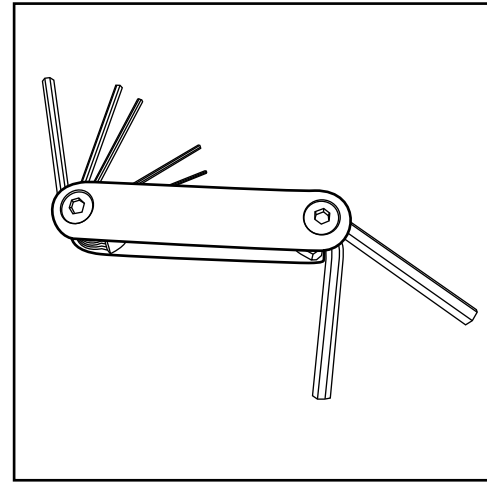

Hex Tool - Essential for Assembly

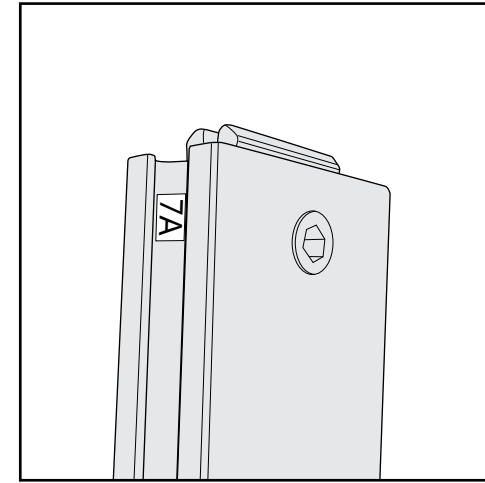

Part Identification - Numbering

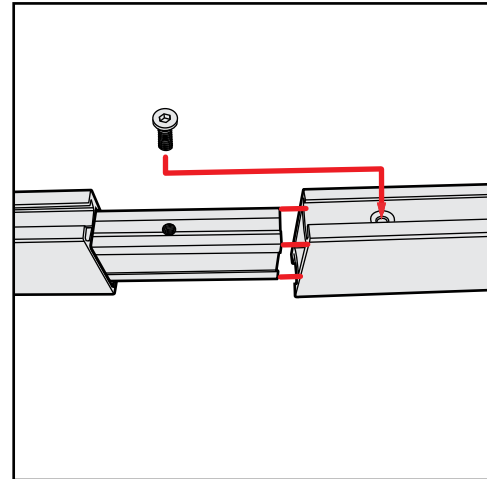

Spline Connection

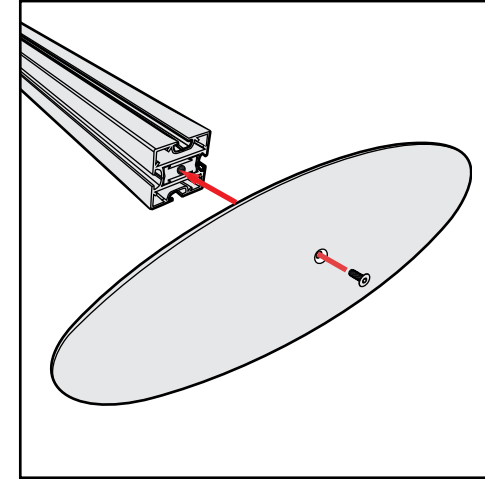

Base Plate & Extrusion Connection

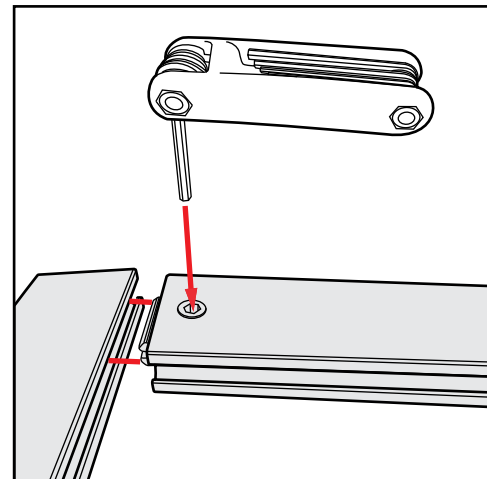

Extrusion & Lock Connection

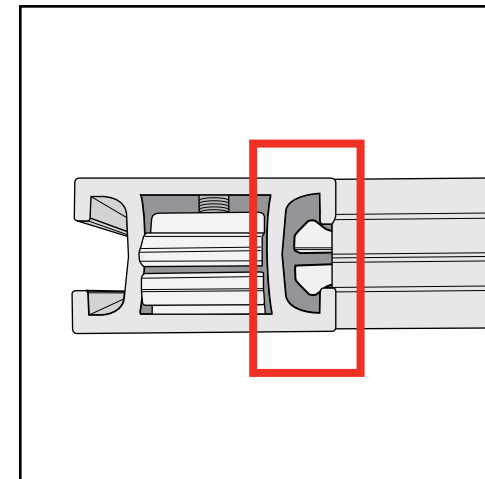

Engaged Lock



WARNING

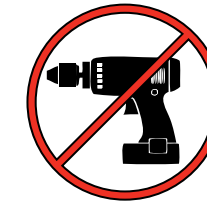

DO NOT USE POWER TOOLS

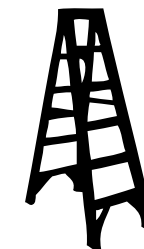

LADDERS OR LIFTS
MAY BE REQUIRED



ALL CONNECTIONS MUST
BE TIGHTLY SECURED

Straight Connection

When assembling frame, first attach all **straight connectors**, then attach **corner connectors**.

- 1) Place extrusions end-to-end.
- 2) Loosen all knobs, then slide **straight connectors** across the seam of extrusions.
- 3) Tighten all knobs to secure connection.

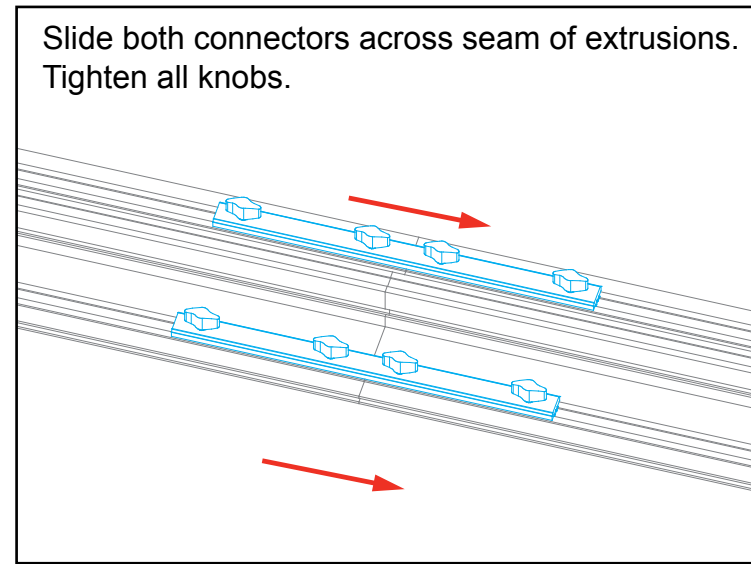
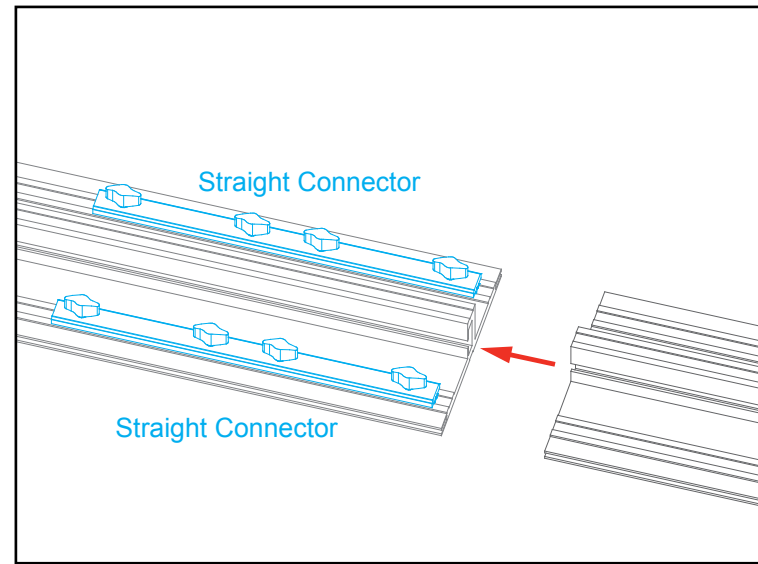

All knobs must be tightened securely to ensure a proper connection.

Disassembly

- 1) Loosen all knobs.
- 2) Slide connectors off of one extrusion.
- 3) Tighten knobs to prevent loss during packing & shipping.

Keep straight connectors in groove of extrusion. Do not remove connectors during disassembly.

Corner Connection

- 1) Loosen knobs, then slide vertical extrusions onto **corner connectors** of **lower** horizontal extrusion.
- 2) Slide **corner connectors** of **upper** horizontal extrusion into grooves of vertical extrusions.
- 3) Tighten all knobs to secure connection.

Disassembly

- 1) Loosen knobs on vertical extrusions.
- 2) Slide the vertical extrusions off of **corner connectors** on lower and upper horizontal extrusions.

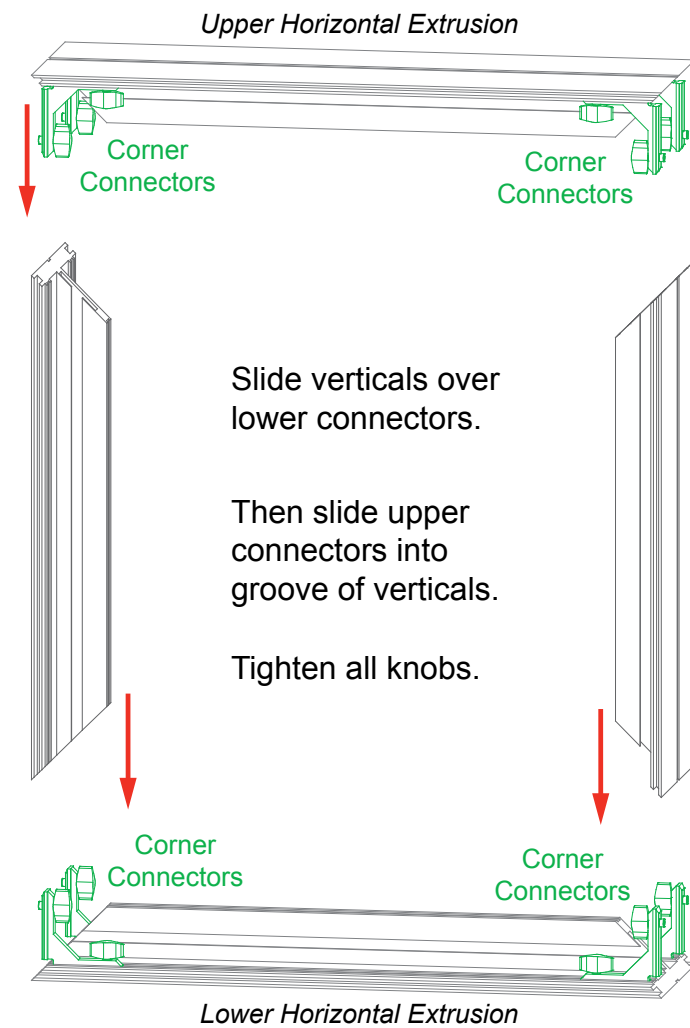

Adjust connectors if necessary to prevent gaps in connection.

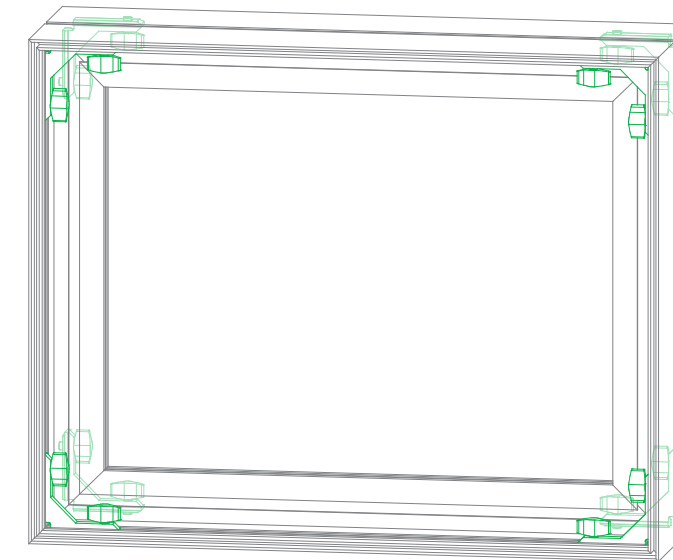

COMPLETED ASSEMBLY

All knobs must be tightened securely to ensure a proper connection.

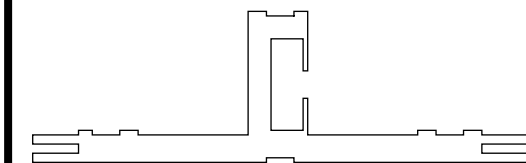

CEI152 Profile

Straight Connection

When assembling frame, first attach all **straight connectors**, then attach **corner connectors**.

- 1) Place extrusions end-to-end.
- 2) Loosen all knobs, then slide **straight connector** across the seam of extrusions.
- 3) Tighten all knobs to secure connection.

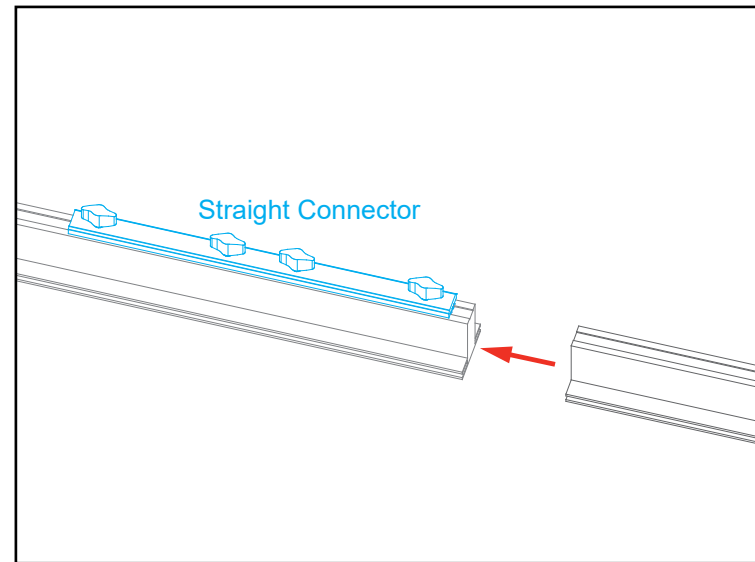

Slide connector across seam of extrusions.
Tighten all knobs.

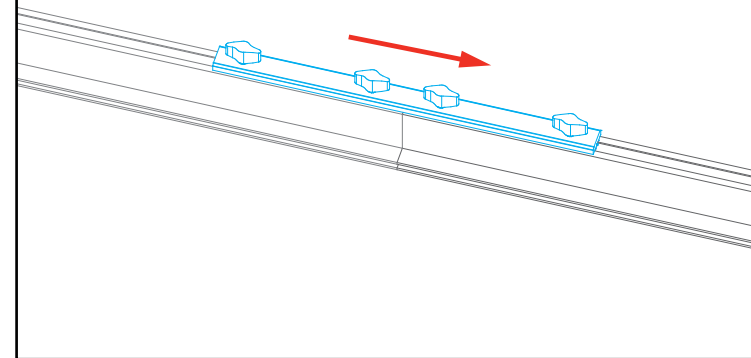

Disassembly

- 1) Loosen all knobs.
- 2) Slide connectors off of one extrusion.
- 3) Tighten knobs to prevent loss during packing & shipping.

Keep straight connectors in groove of extrusion. Do not remove connectors during disassembly.

All knobs must be tightened securely to ensure a proper connection.

Corner Connection

- 1) Loosen knobs, then slide vertical extrusions onto **corner connectors** of **lower** horizontal extrusion.
- 2) Slide **corner connectors** of **upper** horizontal extrusion into grooves of vertical extrusions.
- 3) Tighten all knobs to secure connection.

Disassembly

- 1) Loosen knobs on vertical extrusions.
- 2) Slide the vertical extrusions off of **corner connectors** on lower and upper horizontal extrusions.

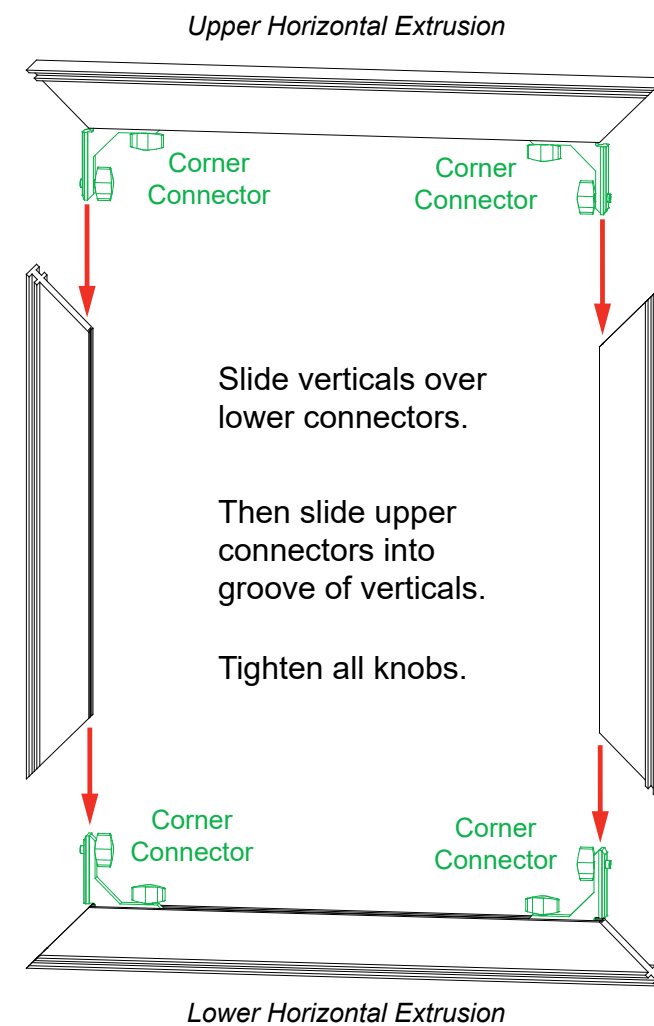

Slide verticals over lower connectors.

Then slide upper connectors into groove of verticals.

Tighten all knobs.



Adjust connectors if necessary to prevent gaps in connection.

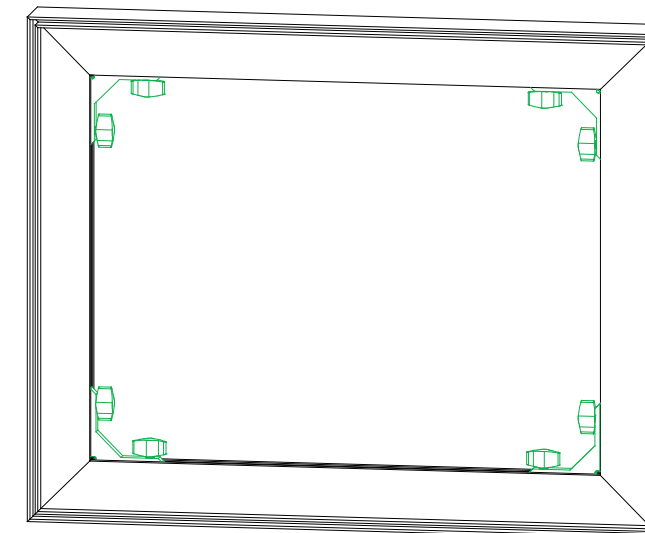

COMPLETED ASSEMBLY

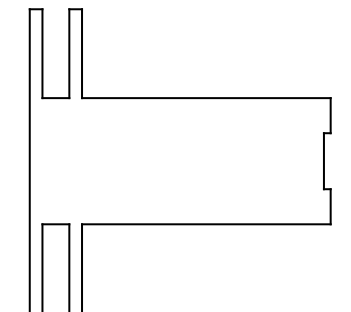

TSP49 Profile

All knobs must be tightened securely to ensure a proper connection.

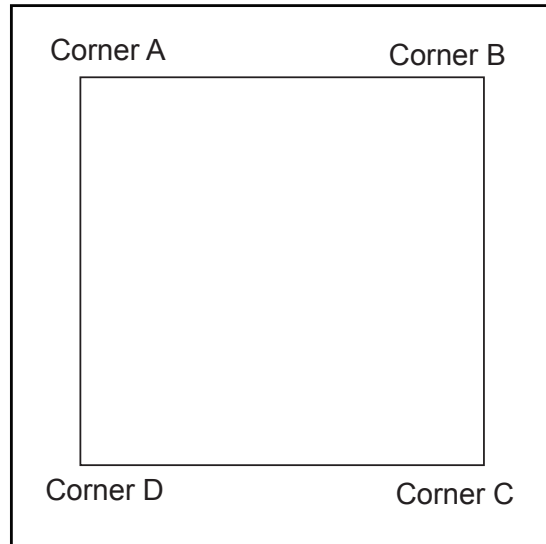

It is important to first insert graphic into each alternate corner then to the sides of the frame. If this is not done, graphic will not fit into the frame correctly.

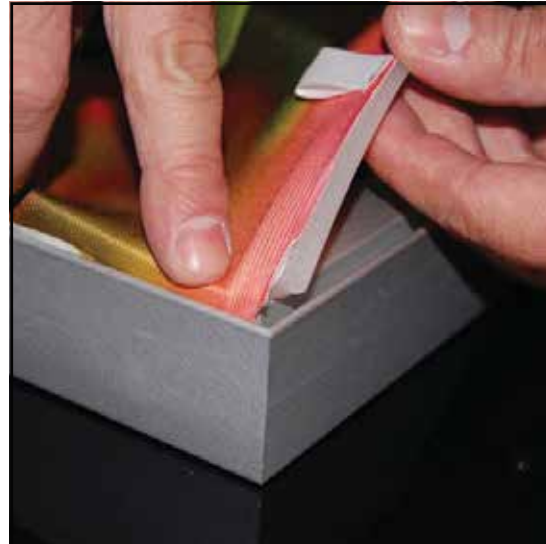

Step 1
Insert corner A. Turn edge of graphic so silicon welt is perpendicular to face of graphic. Insert narrow side of welt with fabric to outside into the channel. Repeat for other side of this corner.



Step 2
Repeat Step 1 for opposite corner C, then insert corner B, followed by corner D, to complete the installation of the corners.



Step 3
Once all corners are inserted, press one silicon edge into channel from corners and work toward the center. Make sure welt is fully inserted into channel. Continue until all sides are done. Smooth out edges of graphic.

Graphic Removal

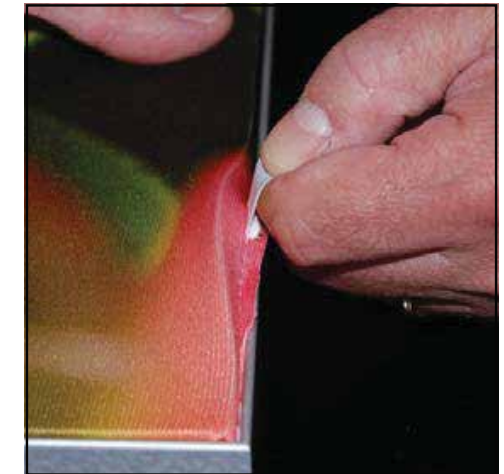

To remove the graphic from the frame, locate the fabric pull tab. Gently pull up on the tab to remove the fabric.

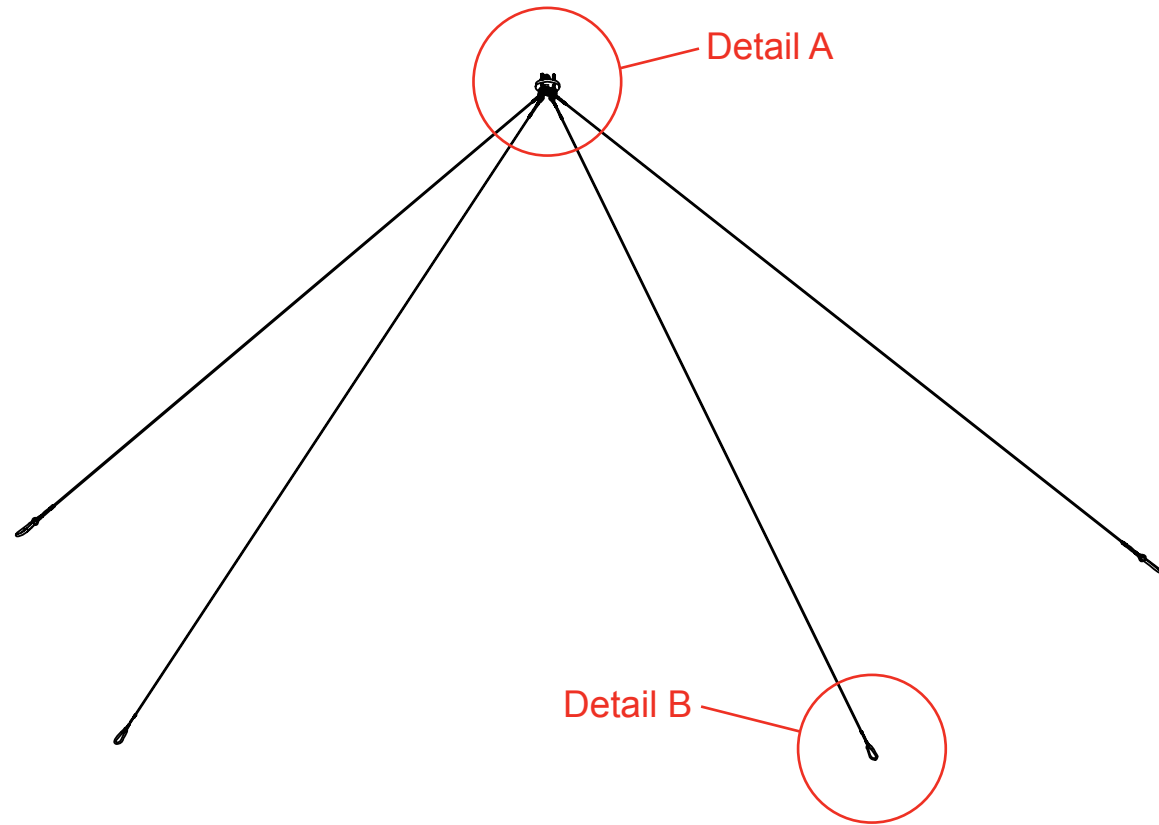

Construction consists of the following materials:

1. 302/304 (1/8") Stainless Steel Cable (Rated at 1760 lbs break strength)
2. Plated Spring-loaded Interlocking Snaps (Rated at 280 lbs working load)
3. Nicoperss Oval Sleeves (Holding strength rated at 900 lbs)
4. 0.25" x 4" Diameter T6061 Aluminum Plate
5. Eye Bolts (Rated 900 lbs on vertical lift and 450 lbs on 45 degree lift)

Harness Strength Calculation:

Hanging sign weight is calculated based on weight of the structure and the weight of the fabric:

1. The weight of the structure material is 0.29 lbs per linear feet
2. The weight of the fabric is 0.04 lbs per sq. feet

Based on information above, one string of the harness at a standard 90 degree sling angle will accommodate 163 sq. feet surface measured sign. The vertical string will hold 233 sq. feet surface measured sign.

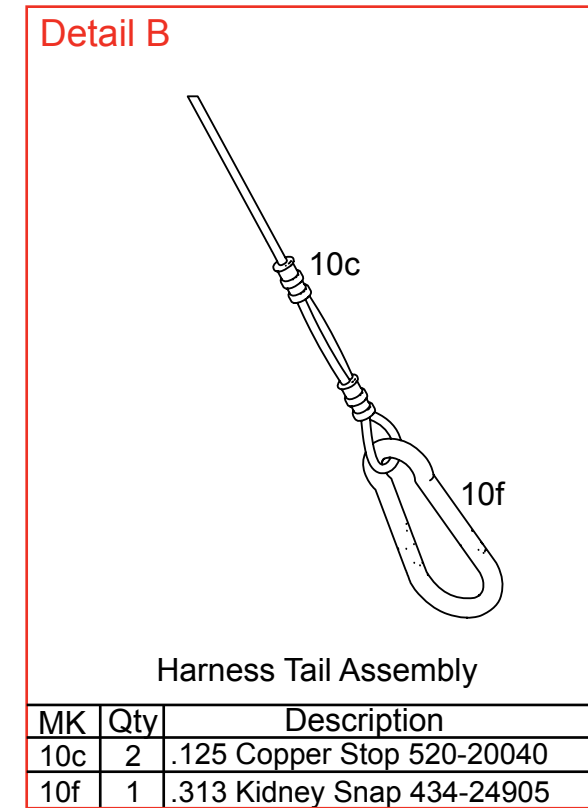
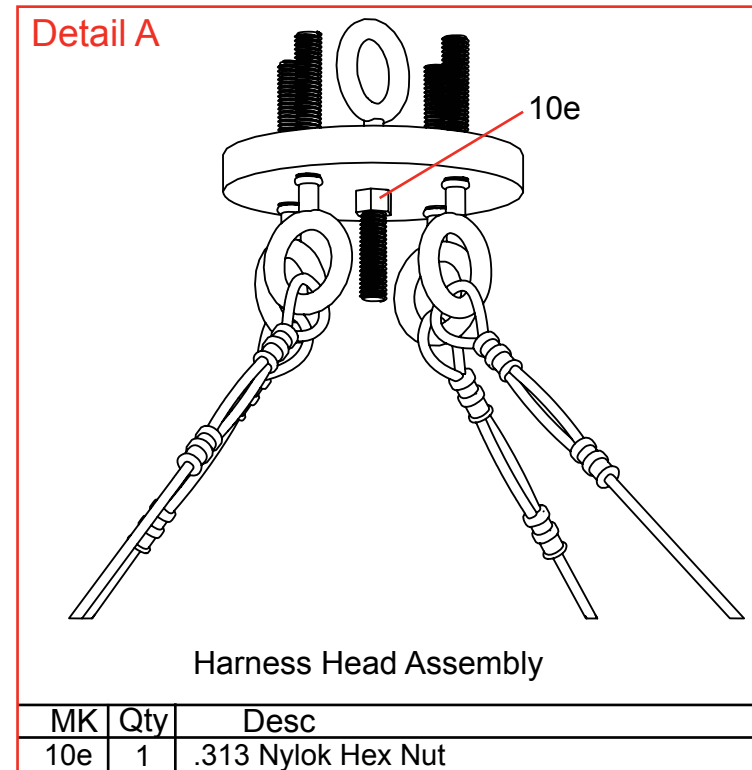

Top View of Each Level

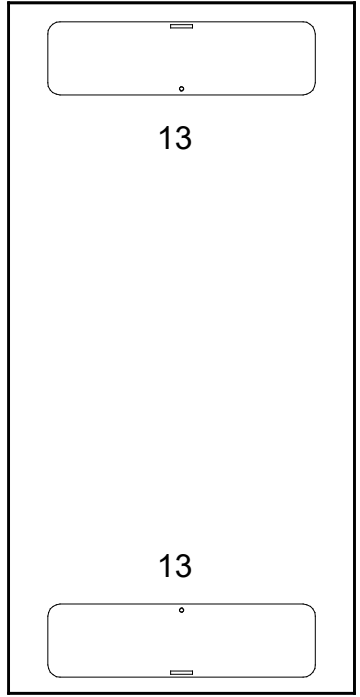

Level 1
(Bottom level)

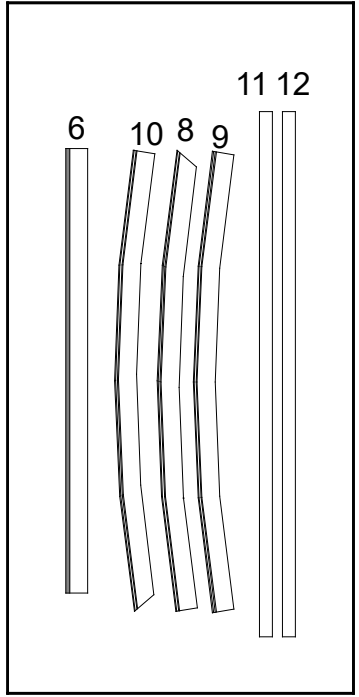

Level 2

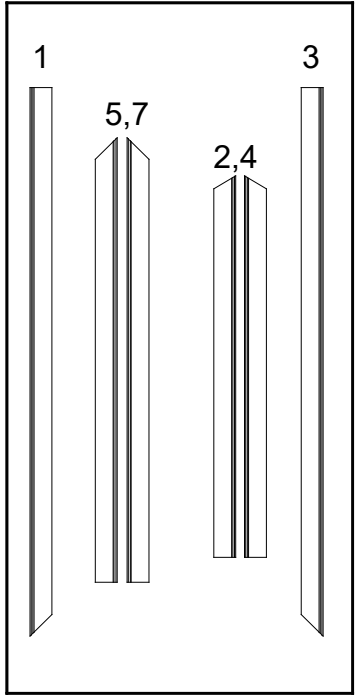

Level 3

Setup Hardware

Graphics

Top View of Each Level

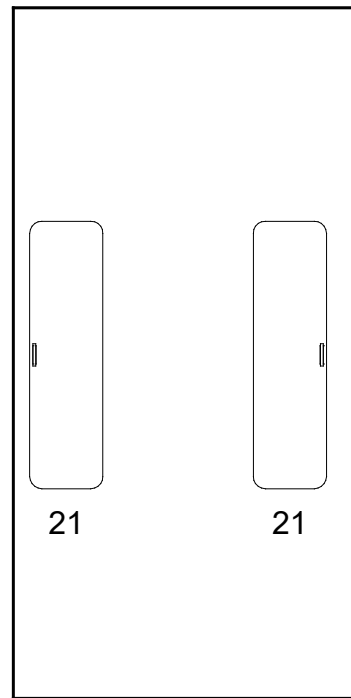

Level 1
(Bottom level)

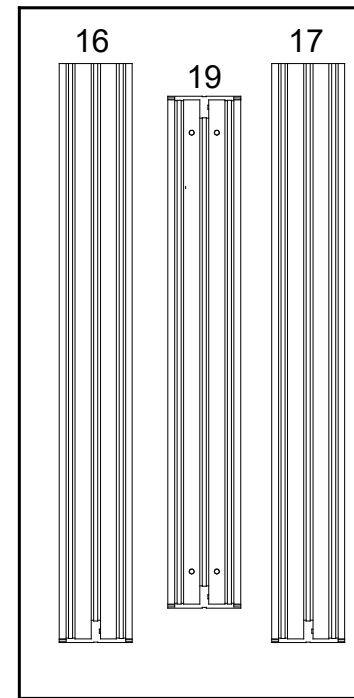

Level 2

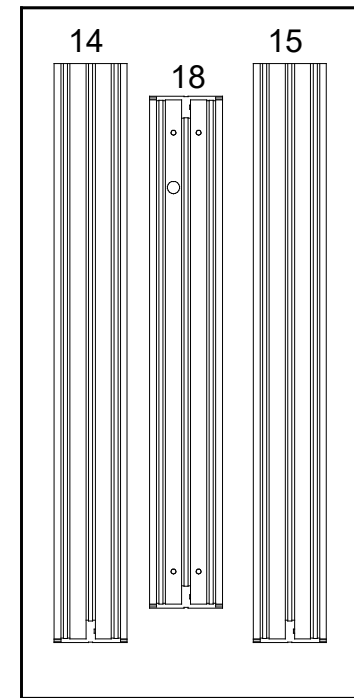

Level 3

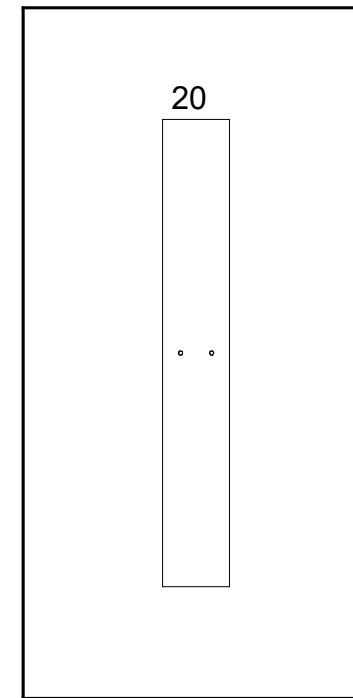

Level 4

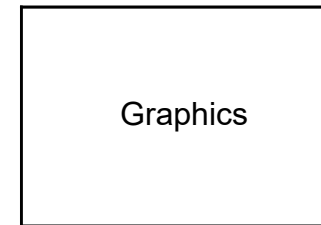

Top View of Each Level

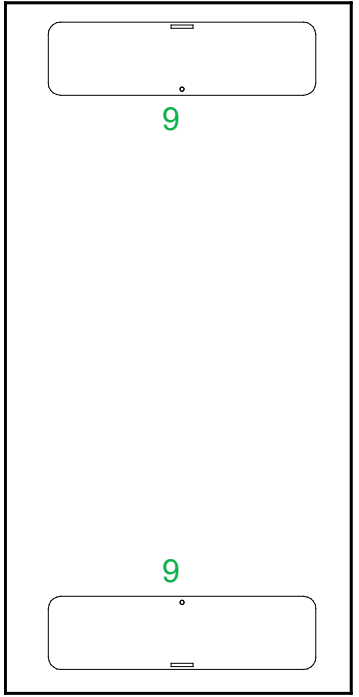

Level 1
(Bottom level)

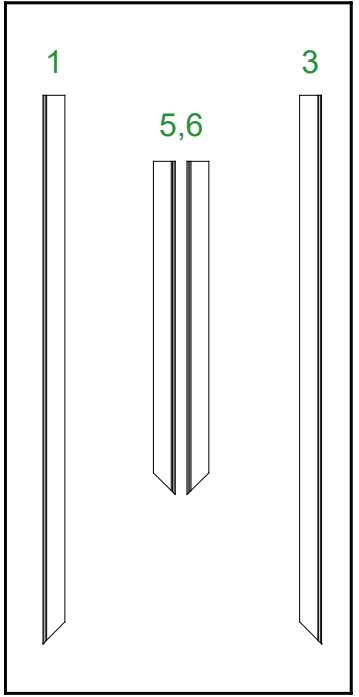

Level 2

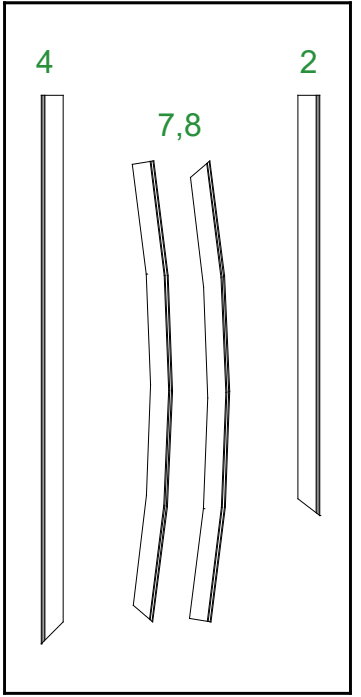

Level 3

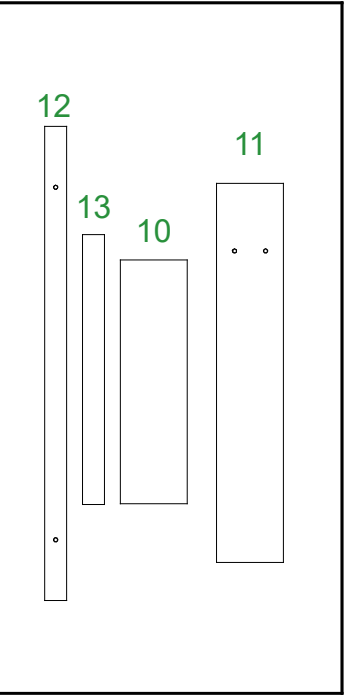

Level 4

Graphics

Setup Hardware
Monitor Mount

Top View of Each Level

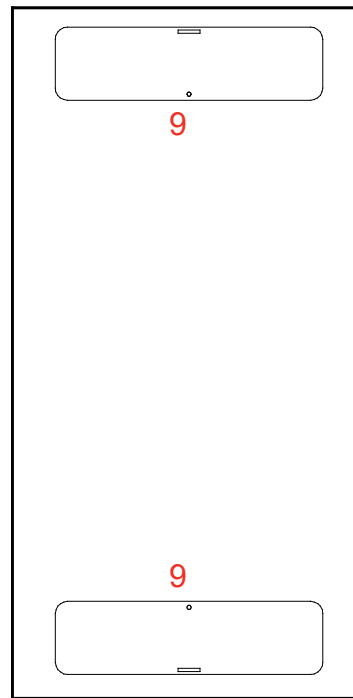

Level 1
(Bottom level)

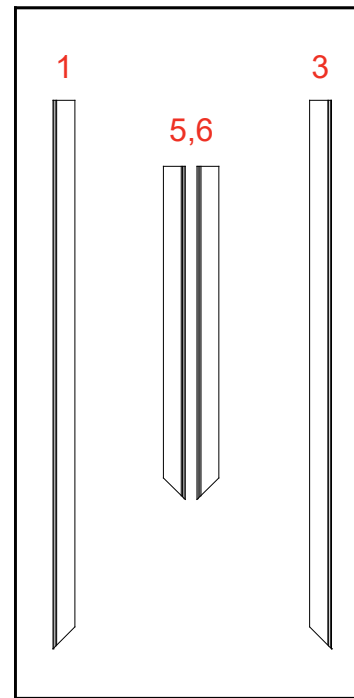

Level 2

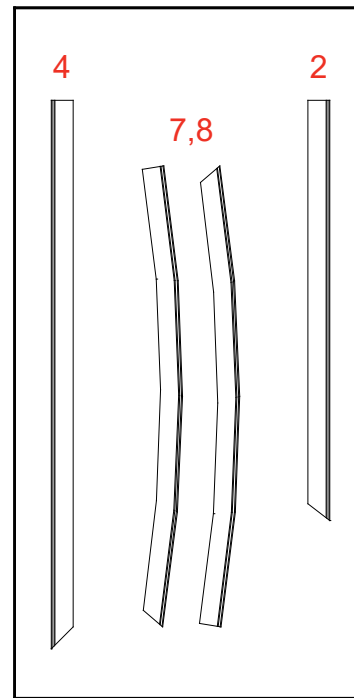

Level 3

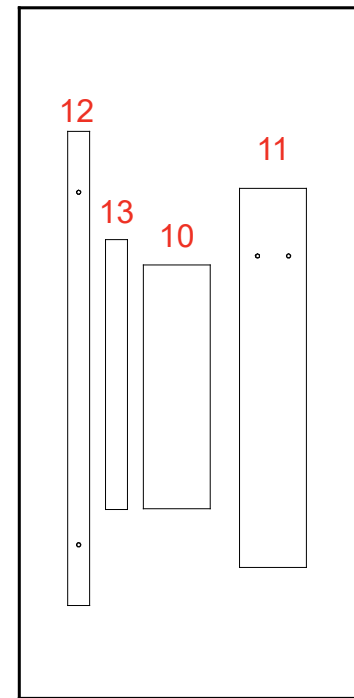

Level 4

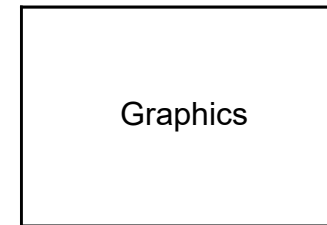

Top View of Each Level

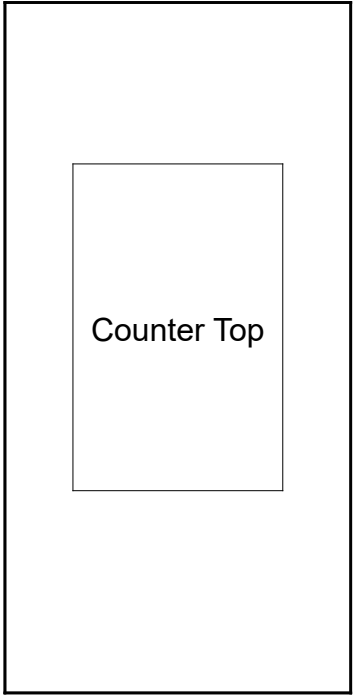

Level 1
(Bottom level)

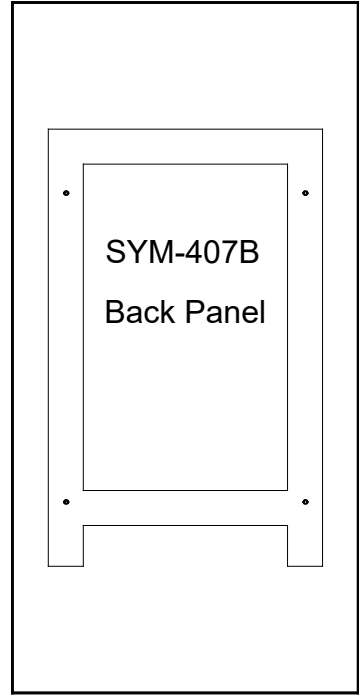

Level 2

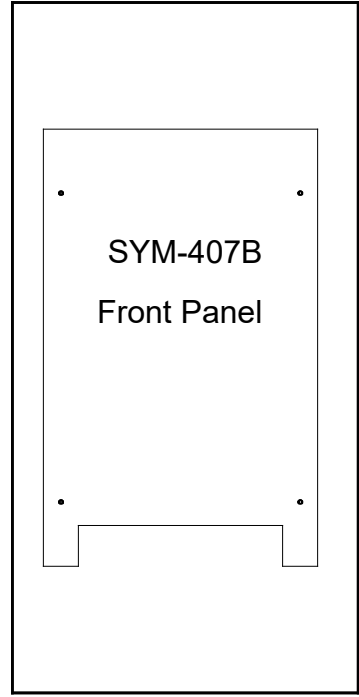

Level 3

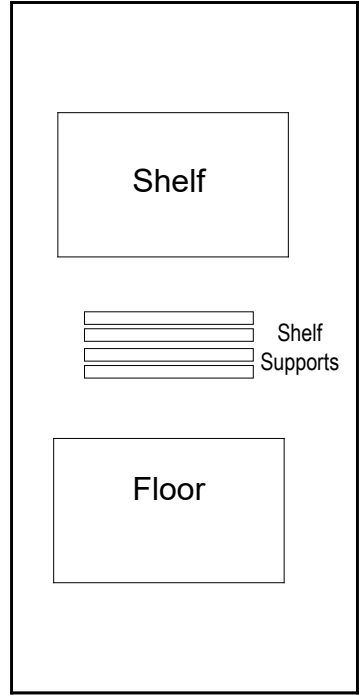

Level 4

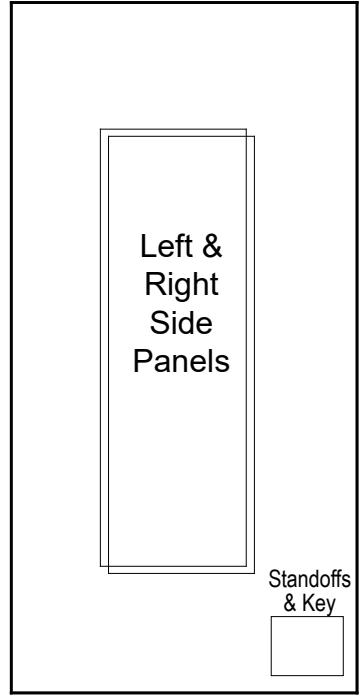

Level 5

Top View of Each Level

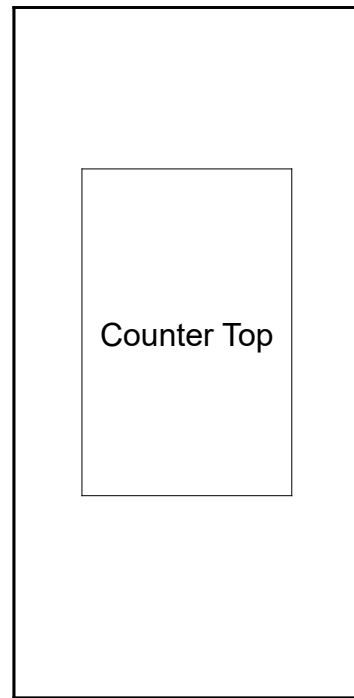

Level 1
(Bottom level)

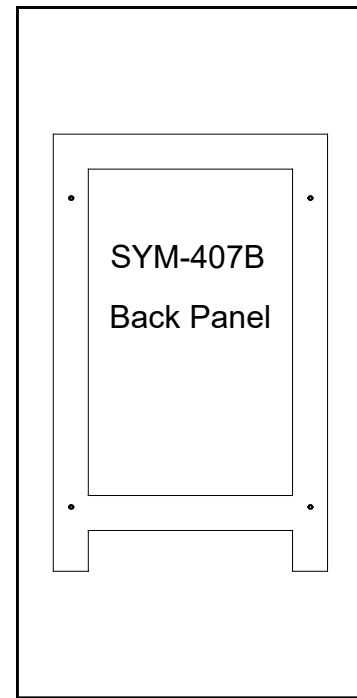

Level 2

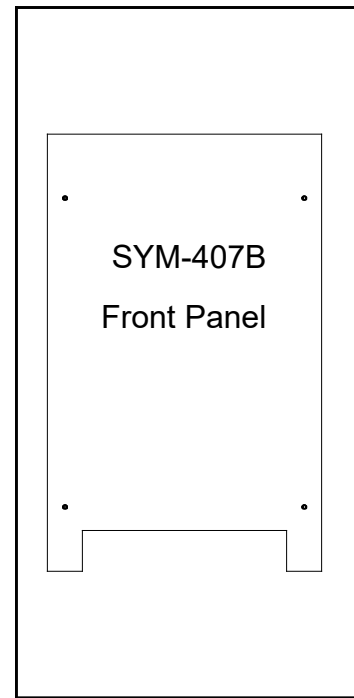

Level 3

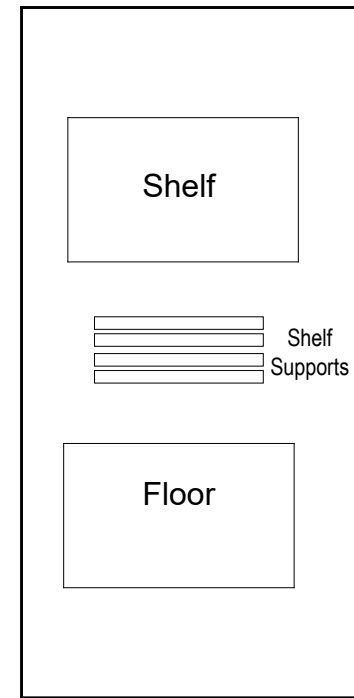

Level 4

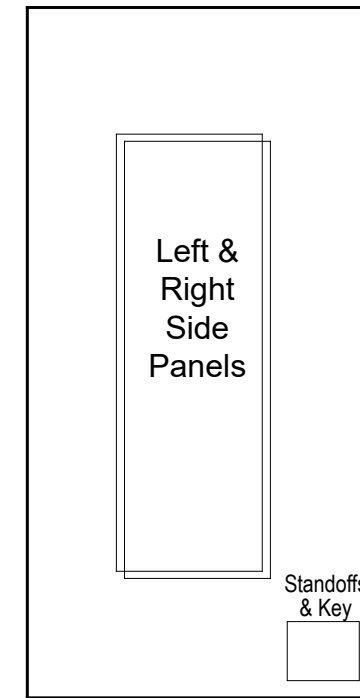

Level 5

Top View of Each Level

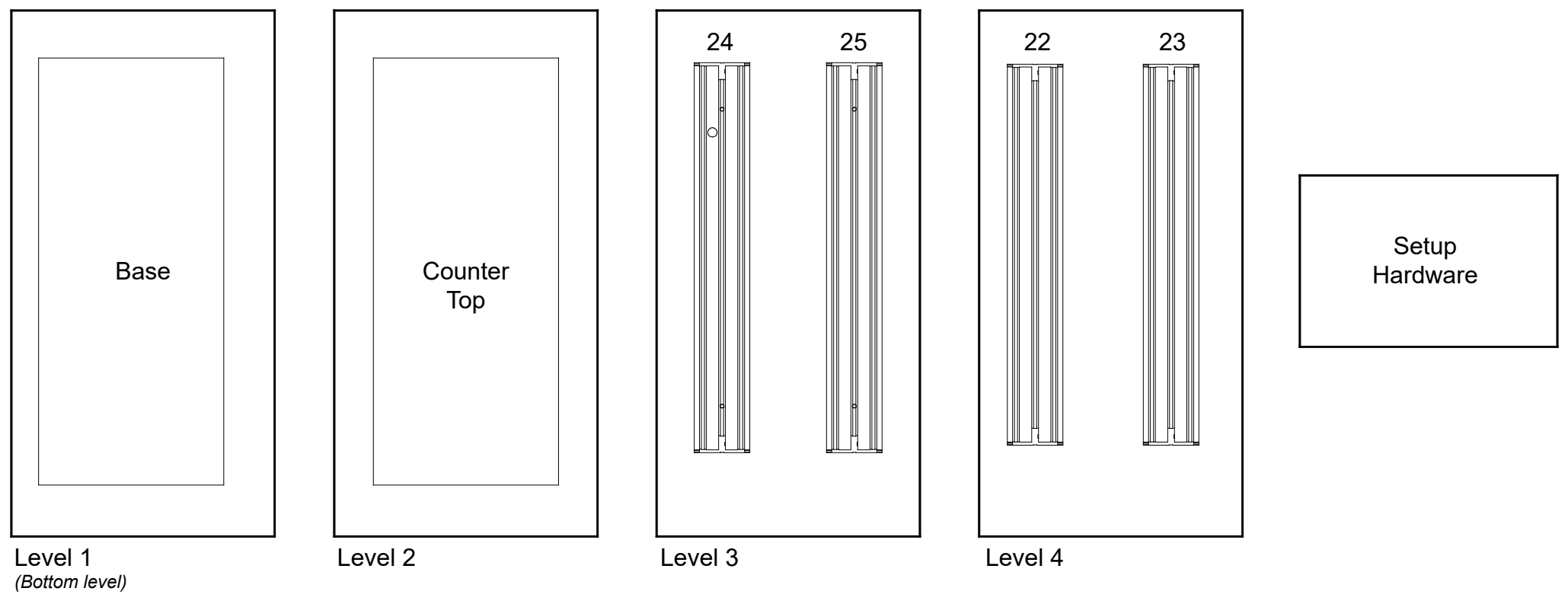

AERO

Using Your Setup Instructions

The Aero Setup Instructions are created specifically for your configuration. The instructions include an exploded view of the frame which is sequentially labeled. We encourage you to review the instructions before attempting to assemble your exhibit.

Connections are kept very simple; no tools required. Everything assembles with push-button connectors.

Cleaning and Packing Your Display

- 1) Use care when cleaning aluminum extrusion or acrylic inserts. Use only non-abrasive cleaners.
- 2) Retain all packing material. It will make re-packing much easier and will reduce the likelihood of shipping damage.

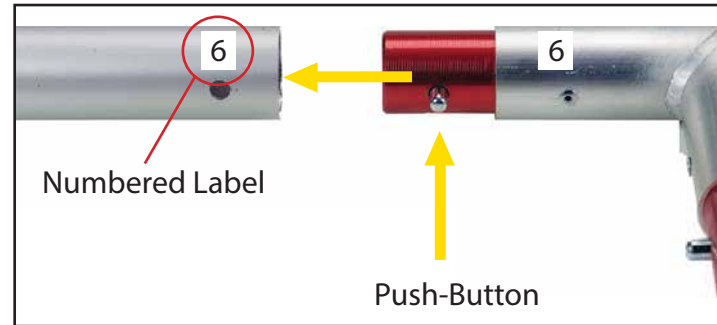

Connections are made by holding the button down and sliding the red tube into opposing tube until button locks into the hole of the opposing tube. To disassemble, push button and pull or twist extrusions apart.

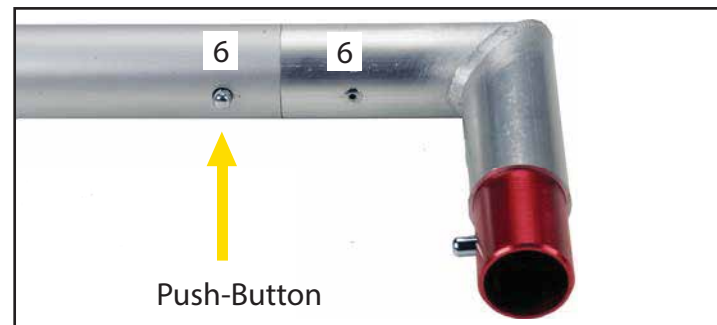

Steps:

- 1) Assemble Aero Frame parts labeled [1 through 24] & [25 through 48] together in numerical order, as shown.
- 2) Connect verticals [V] between upper & lower assemblies.
- 3) Apply Pillowcase Graphic to assembled frame.

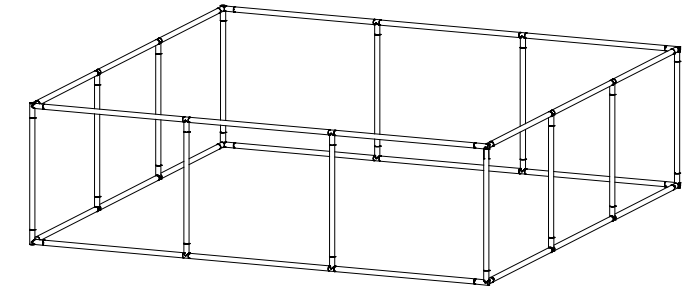

When assembled

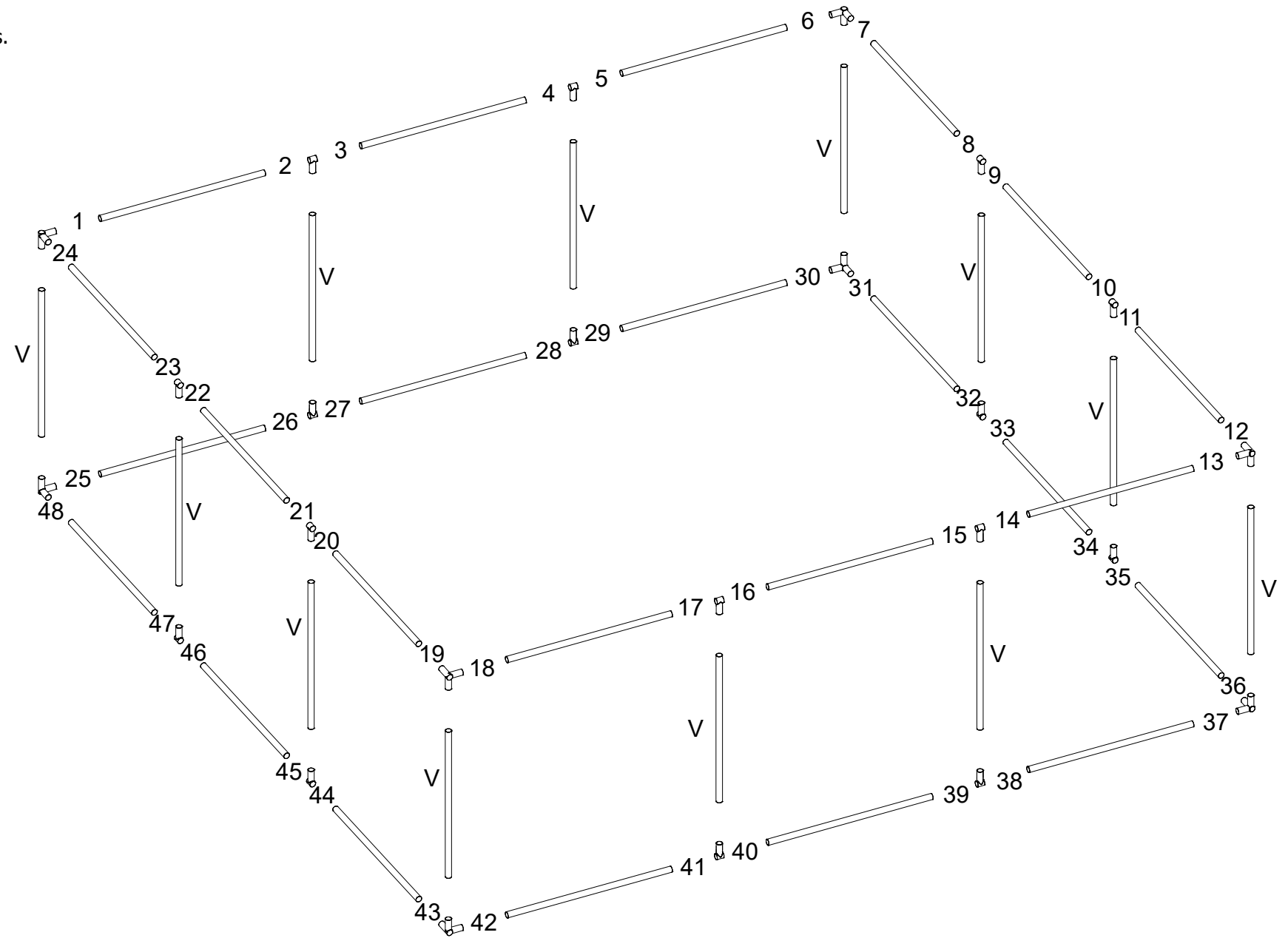

Item	Qty.	Description
1	1	45"h TSP49 Vertical Extrusion
2	1	31.305"h TSP49 Vertical Extrusion
3	1	45"h TSP49 Vertical Extrusion
4	1	31.305"h TSP49 Vertical Extrusion
5	1	36.467"w TSP49 Horizontal Extrusion
6	1	36.467"w TSP49 Horizontal Extrusion
7	1	36.467"w TSP49 Horizontal Extrusion
8	1	38.019"w TSP49 curved Horizontal Extrusion
9	1	38.019"w TSP49 curved Horizontal Extrusion
10	1	38.019"w TSP49 curved Horizontal Extrusion
11	1	45.209"h Z45 Vertical Extrusion
12	1	41.209"h Z45 Vertical Extrusion
13	2	6" x 22" End Base Plate w/ foot

Steps:

Refer to the *Tool-less Frame Assembly* general information page.

- 1) Assemble vertical extrusions [1-2], [3-4], [11-12] & horizontals [5-6-7], [8-9-10] together, using **Tool-less Spline connectors** labeled [X] & [Y].
- 2) Connect vertical assemblies [1/2], [3/4] between horizontal assemblies [5/6/7], [8/9/10], using **Tool-less Corner Connectors** labeled [A] & [B].
- 3) Install Base Plates [13] to bottom corners of frame assembly as shown. See **Base Plate Attachment** detail.
- 4) Lift frame to upright position, then connect vertical assembly [11/12] between horizontal assemblies [5/6/7], [8/9/10] using cam locks.

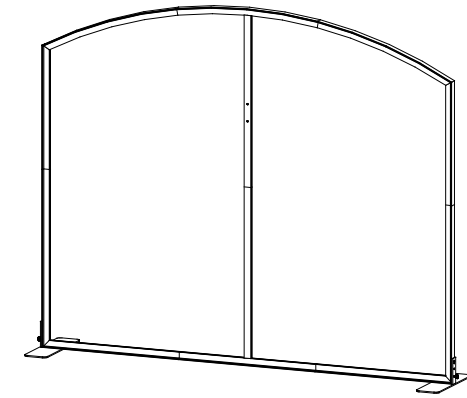

When assembled

Assemble frame flat on ground.

*** Tool-less Spline Connector**

1. Place extrusions end-to-end.
2. Slide tool-less connectors across seam of extrusions.
3. Tighten all knobs to secure connection.

*** Tool-less Corner Connector**

1. Slide extrusion onto Corner Connector.
2. Tighten all knobs to secure connection.

Keep corner connectors attached to horizontal extrusions.

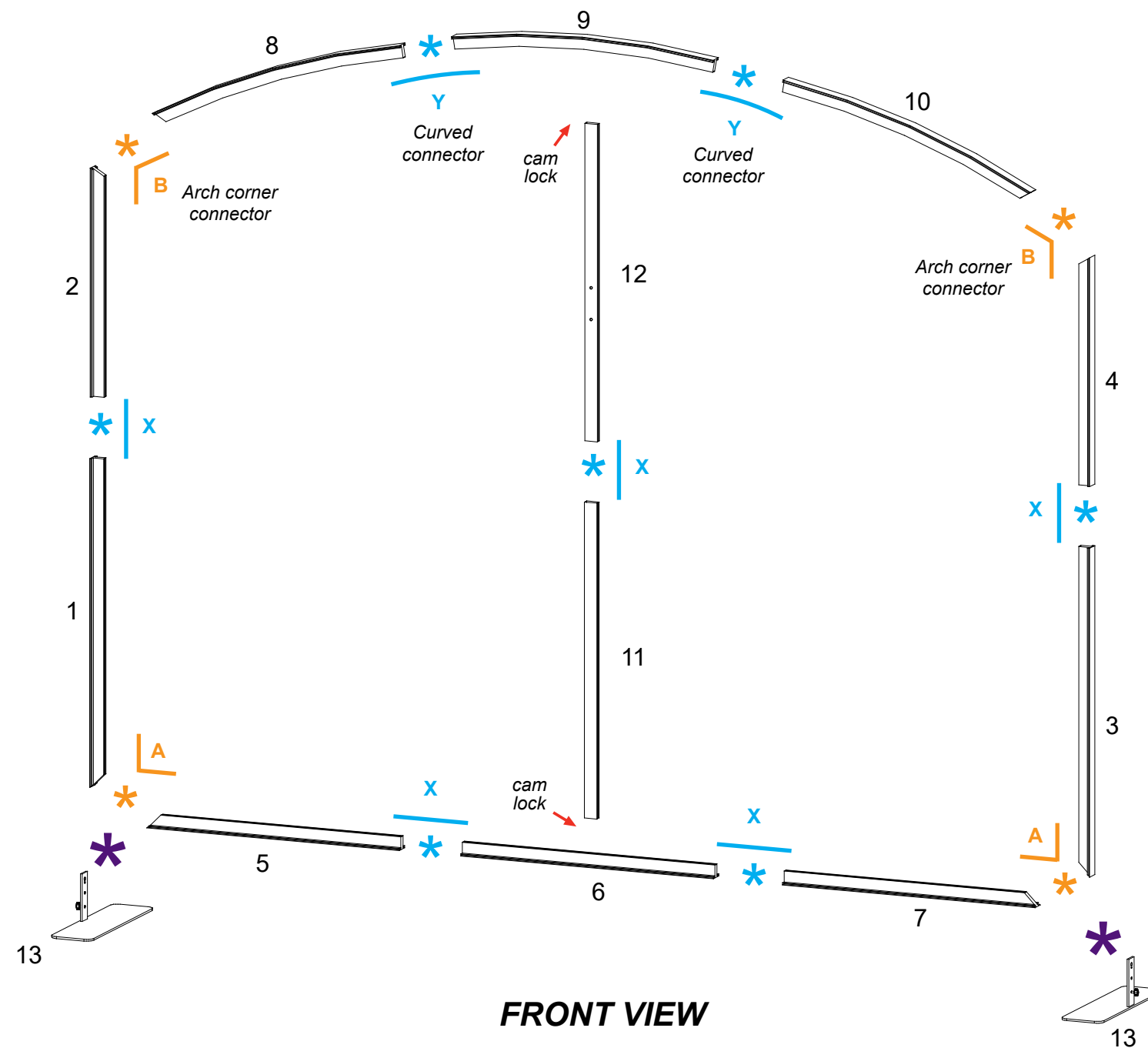

*** Base Plate Attachment**

- 1) Place key hole over bolt on panel & slide down.
- 2) Twist knob to secure connection.

SEG Graphic Installation

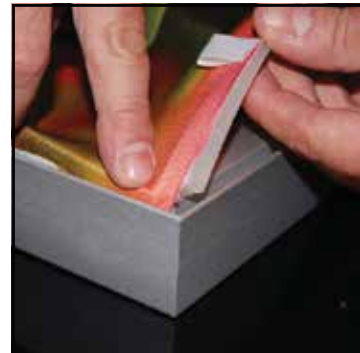
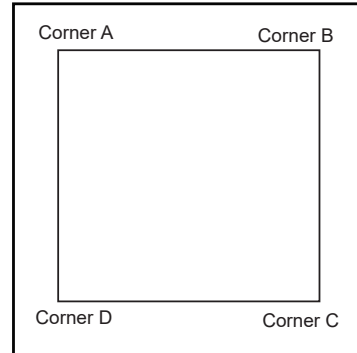

It is important to first insert graphic into each alternate corner, then to the sides of the frame. If this is not done, graphic will not fit into the frame correctly.

Step 1
Insert corner A. Turn edge of graphic so silicon welt is perpendicular to face of graphic. Insert narrow side of welt with fabric to outside into the channel. Repeat for other side of this corner.



Step 2
Repeat Step 1 for opposite corner C, then insert corner B, followed by corner D, to complete the installation of the corners.



Step 3
Once all corners are inserted, press one silicon edge into channel from corners and work toward the center. Make sure welt is fully inserted into channel. Continue until all sides are done. Smooth out edges of graphic.



Graphic Removal
To remove the graphic from the frame, locate the fabric pull tab. Gently pull up on the tab to remove the fabric.

Steps:
1) Apply SEG Graphics to front & back of assembled frame.

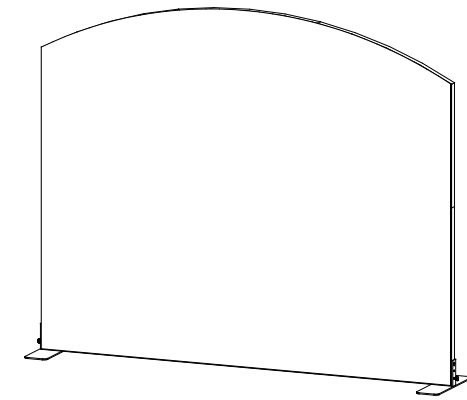

When assembled

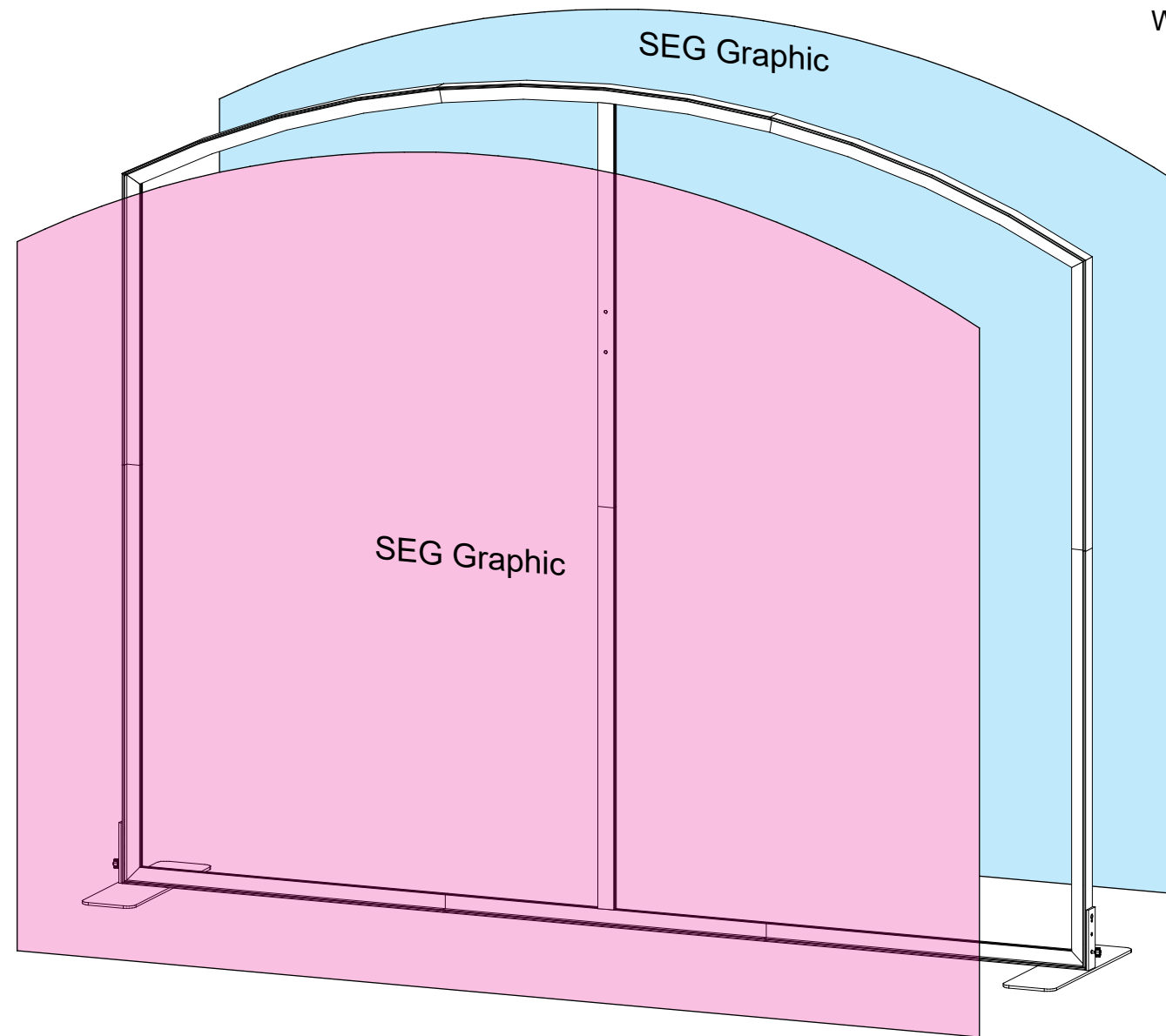

FRONT VIEW

Item	Qty.	Description
14	1	47.5" h CEI152 Vertical Extrusion
15	1	47.5" h CEI152 Vertical Extrusion
16	1	47.5" h CEI152 Vertical Extrusion
17	1	47.5" h CEI152 Vertical Extrusion
18	1	42" w CEI152 Horizontal Extrusion
19	1	42" w CEI152 Horizontal Extrusion
20	1	38.353" w Z140 Horizontal Extrusion
21	2	Base Plate

Steps:

Refer to the CEI152 Frame Assembly general information page.

- 1) Assemble verticals [14-15], [16-17] together using straight connectors.
- 2) Connect vertical assemblies [14/15], [16/17] between horizontals [18,19] using corner connectors.
- 3) Attach horizontal [20] between vertical assemblies.
- 4) Connect Base Plates [21] to frame assembly.
See [Base Plate Attachment](#) detail.
- 5) Connect power cords to Supernova lights as shown.

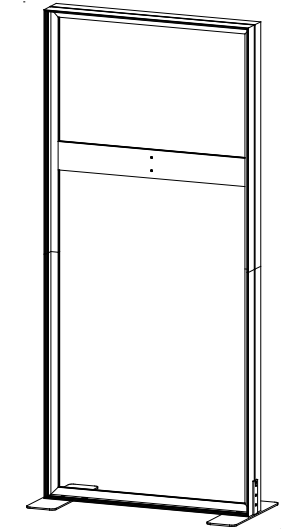

When assembled

Assemble frame flat on ground.

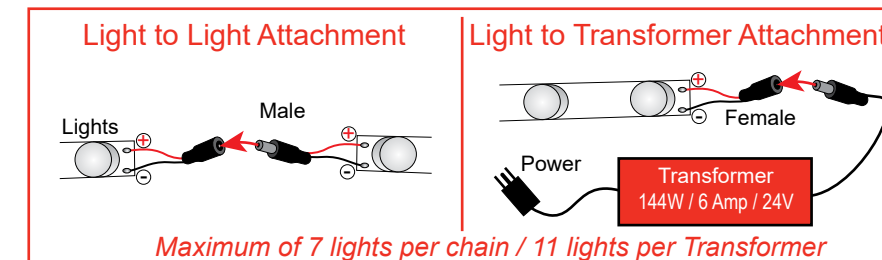
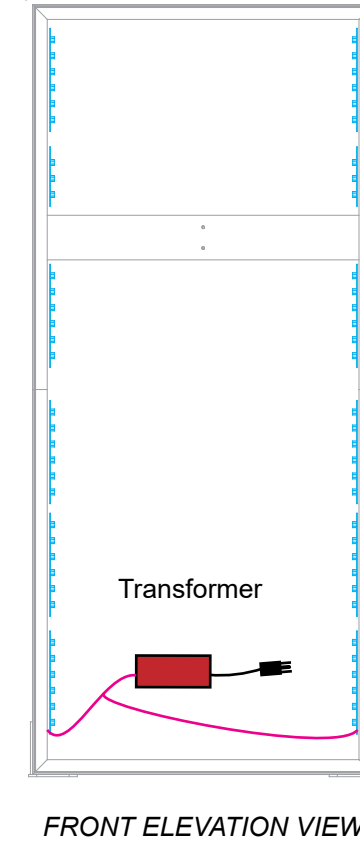
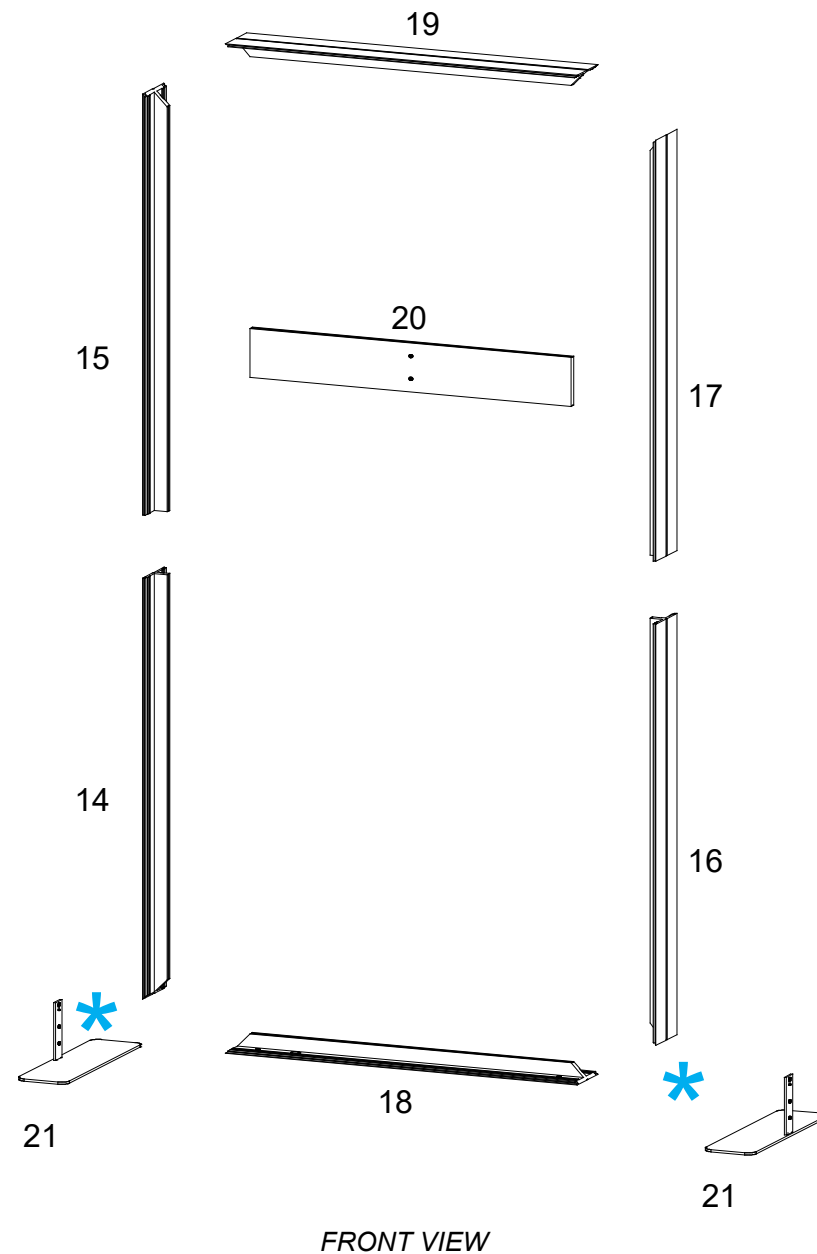
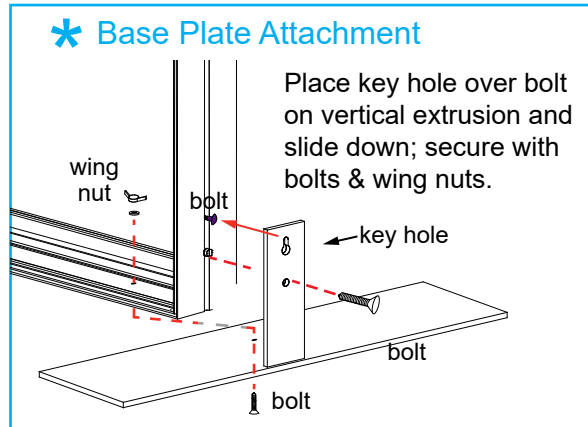

Steps:

- 1) Apply SEG graphic to *front* of frame assembly. Refer to the *SEG Installation general information page*.
- 2) Connect front Monitor Mount to horizontal [20]. See **Monitor Mount Attachment** detail.
- 3) Apply SEG graphic to *back* of frame assembly.
- 4) Connect back Monitor Mount to horizontal [20]. See **Monitor Mount Attachment** detail.

*** Monitor Mount Attachment**

Attach Monitor Mount to horizontal extrusion using standoff barrels, bolts & wing nuts.

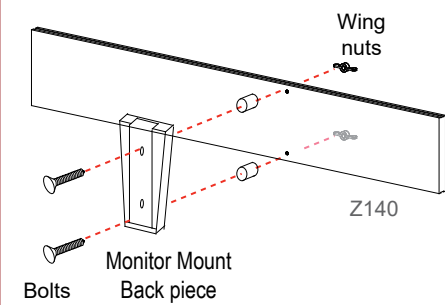
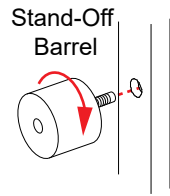

Slide monitor mount into back piece.

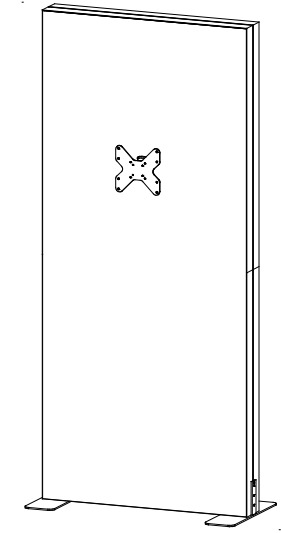

When assembled

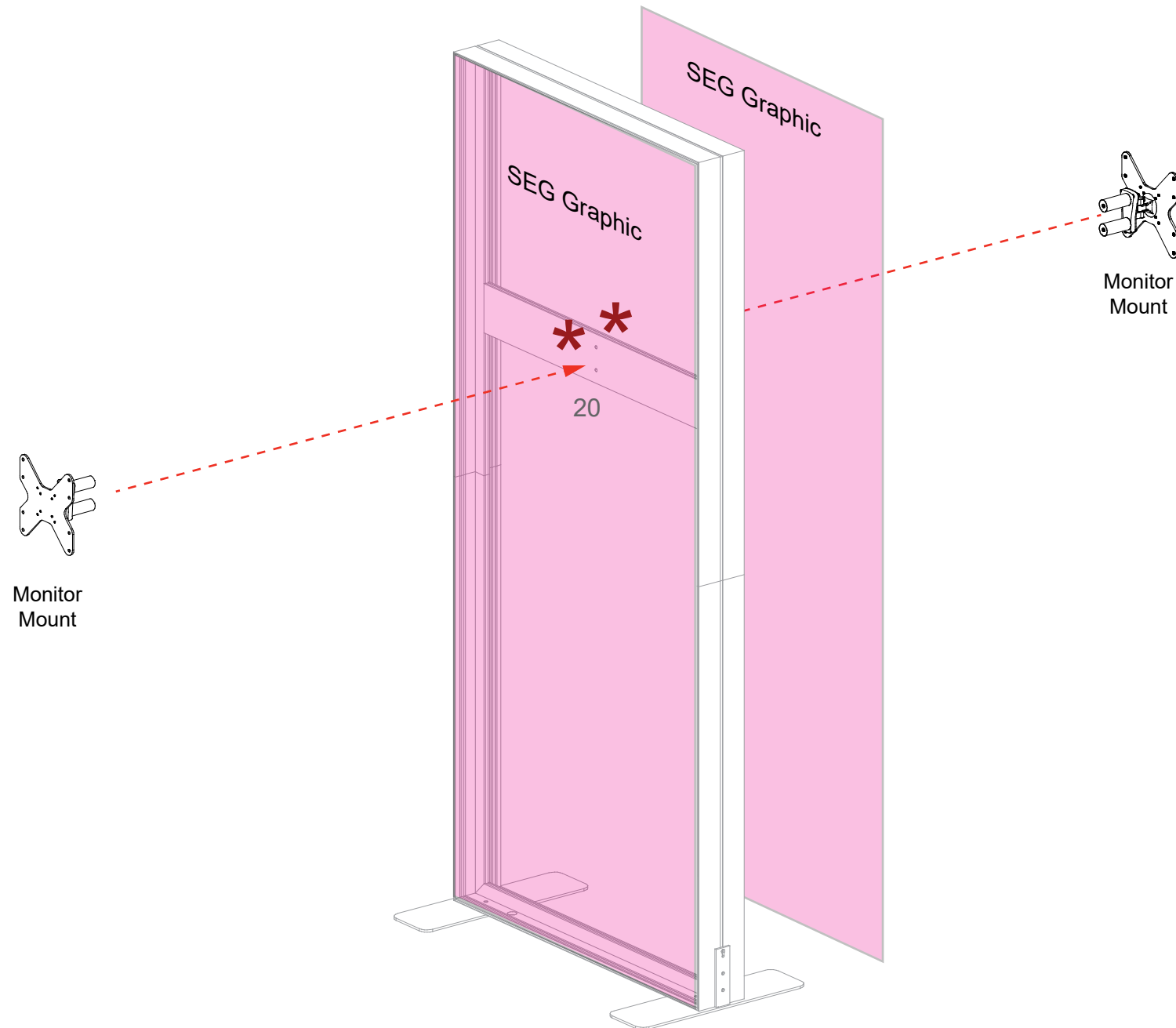

Back Panel Hole Placement

Holes on back panel of Counter are off-center to attach to backwall vertical.

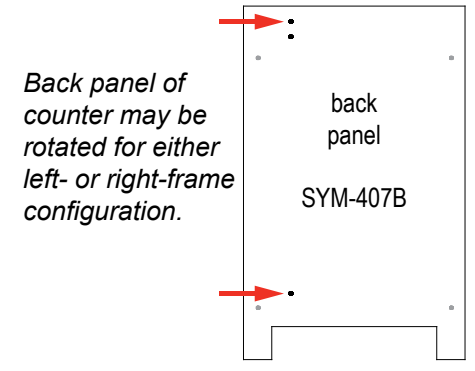

When assembling counter, align holes of back panel to vertical extrusion of backwall frame.
Counter should be *centered* on backwall frame when installed.

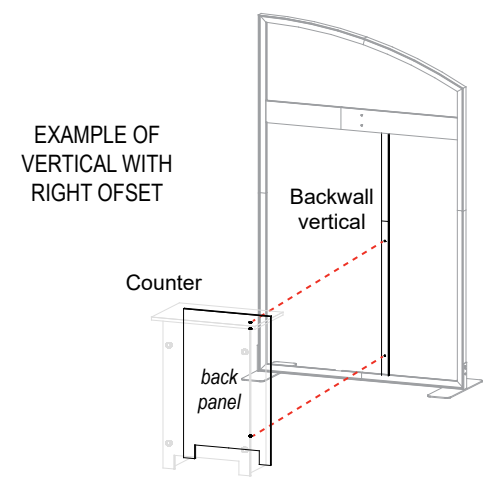
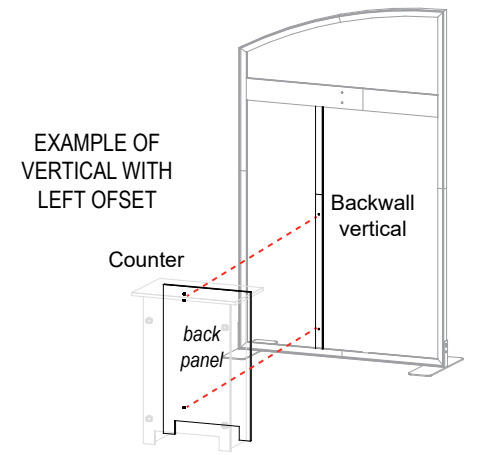

Steps:

- 1) Attach pins at bottom interior of side panels. *Note: Pins are designed to be slightly angled.*
- 2) Use screw caps to secure side panels to front & back panels.
- 3) Slide floor into the bottom of assembled pedestal base. The floor will sit on pins of the side panels.
- 4) Connect **shelf supports** with Velcro inside of panels, then place shelf on top of supports.
- 5) Attach Counter Top to assembled pedestal base. See **Counter Top Attachment** detail.

Repeat steps 1 through 5 for other counter assembly.

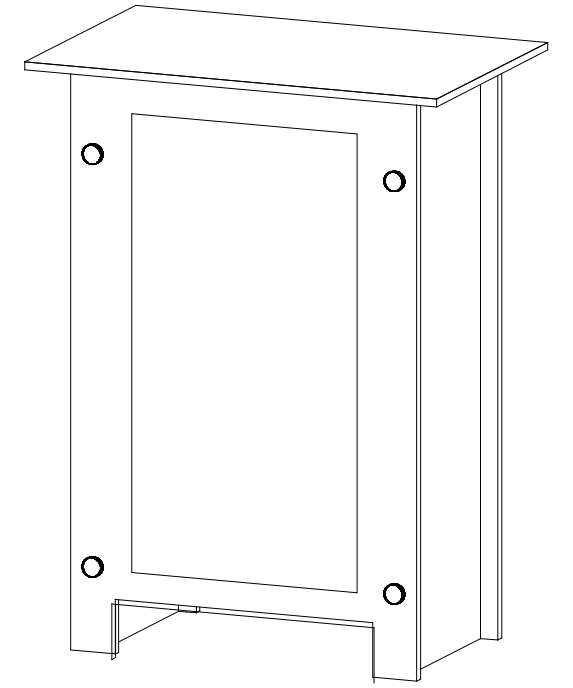
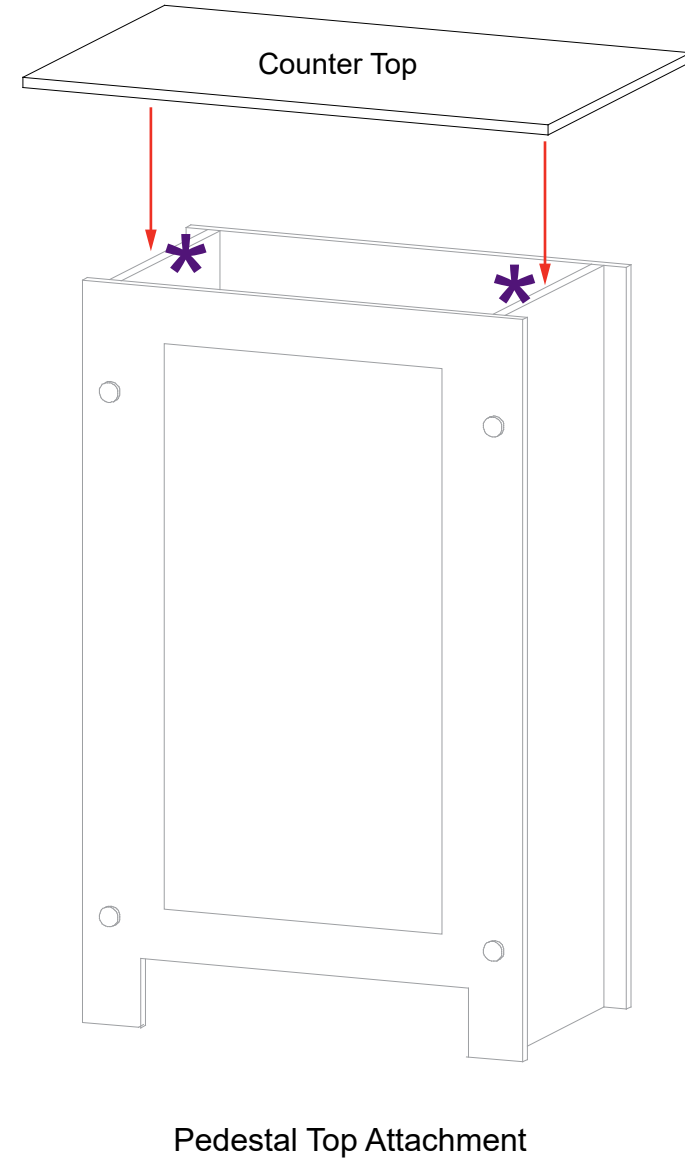
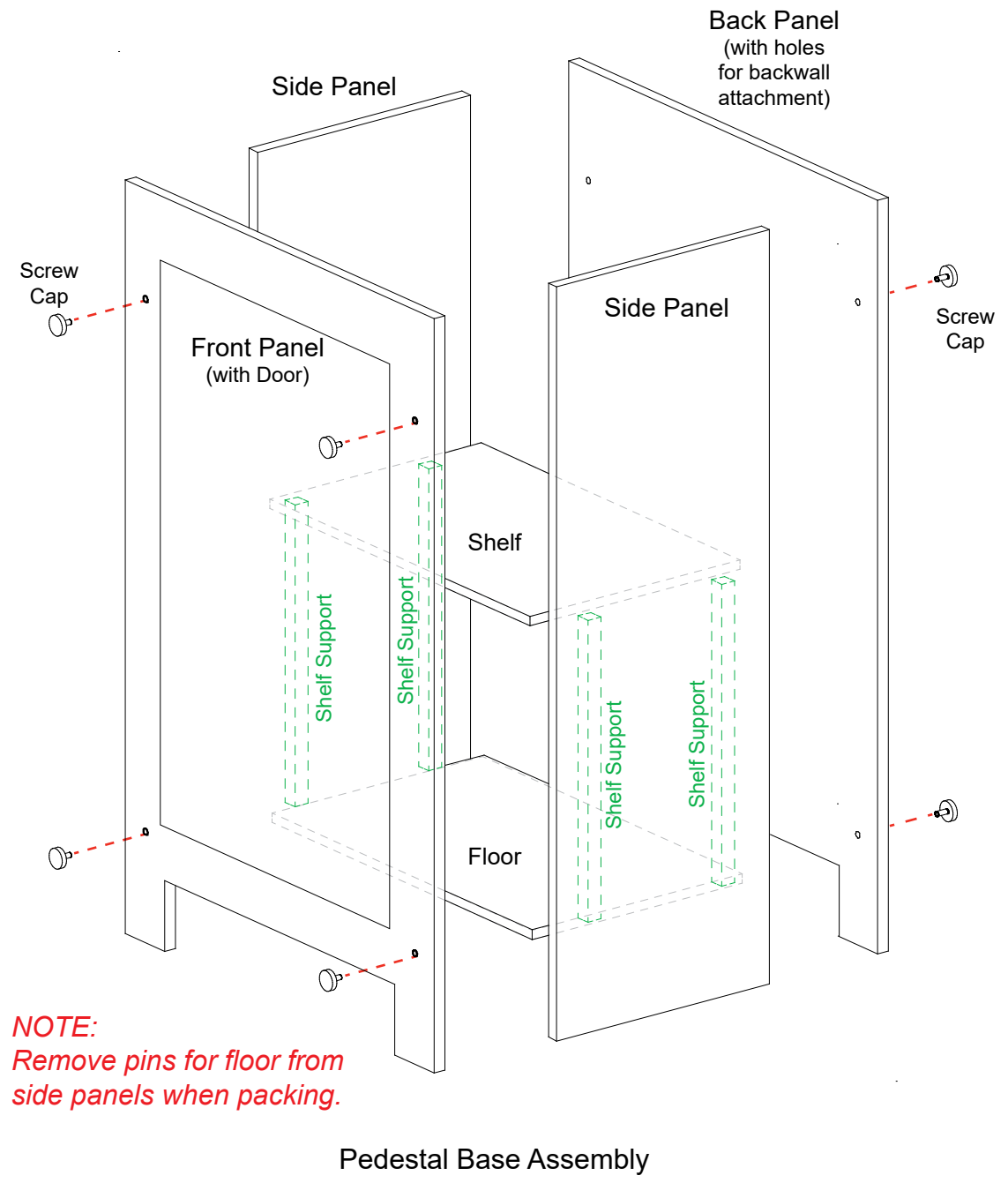

When assembled
SYM-407B Backwall Counter
Qty. 2

*** Counter Top Attachment**

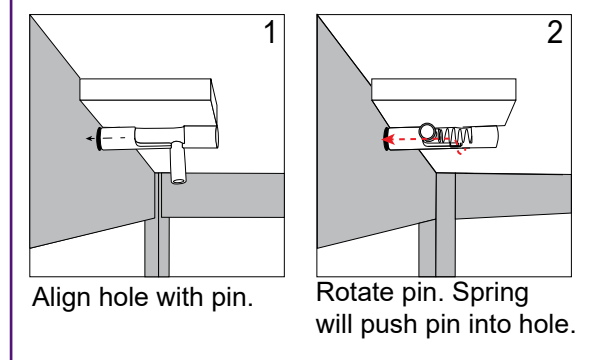

Item	Qty.	Description
1	1	45"h TSP49 Vertical Extrusion
2	1	31.305"h TSP49 Vertical Extrusion
3	1	45"h TSP49 Vertical Extrusion
4	1	45"h TSP49 Vertical Extrusion
5	1	27.35"w TSP49 Horizontal Extrusion
6	1	27.35"w TSP49 Horizontal Extrusion
7	1	28.514"w TSP49 curved Horizontal Extrusion
8	1	28.514"w TSP49 curved Horizontal Extrusion
9	2	6" x 22" End Base Plate w/ foot
10	1	20"w Z140 Horizontal Extrusion
11	1	31.121"w Z140 Horizontal Extrusion
12	1	39"h Z45 Vertical Extrusion
13	1	22.203"h Z45 Vertical Extrusion

Steps:

Refer to the *Tool-less Frame Assembly* general information page.

- 1) Assemble vertical extrusions [1-2], [3-4] & horizontal extrusions [5-6], [7-8] together, using **Tool-less Spline connectors** labeled [X] & [Y].
- 2) Connect vertical assemblies [1/2], [3/4] between horizontal assemblies [5/6], [7/8], using **Tool-less Corner Connectors** labeled [A] & [B].
- 3) Attach horizontals [10-11] between verticals [1/2], [3/4].
- 4) Connect verticals [12-13] between horizontals [5/6] & [10/11].
- 5) Install Base Plates [9] to bottom corners of frame assembly as shown. See **Base Plate Attachment** detail.

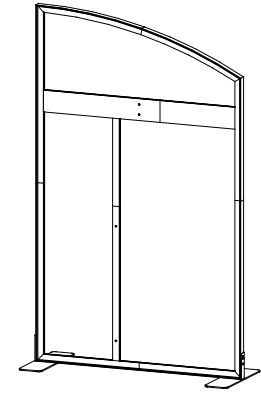

When assembled

Assemble frame flat on ground.

*** Tool-less Spline Connector**

1. Place extrusions end-to-end.
2. Slide tool-less connectors across seam of extrusions.
3. Tighten all knobs to secure connection.

*** Tool-less Corner Connector**

1. Slide extrusion onto Corner Connector.
2. Tighten all knobs to secure connection.

Keep corner connectors attached to horizontal extrusions.

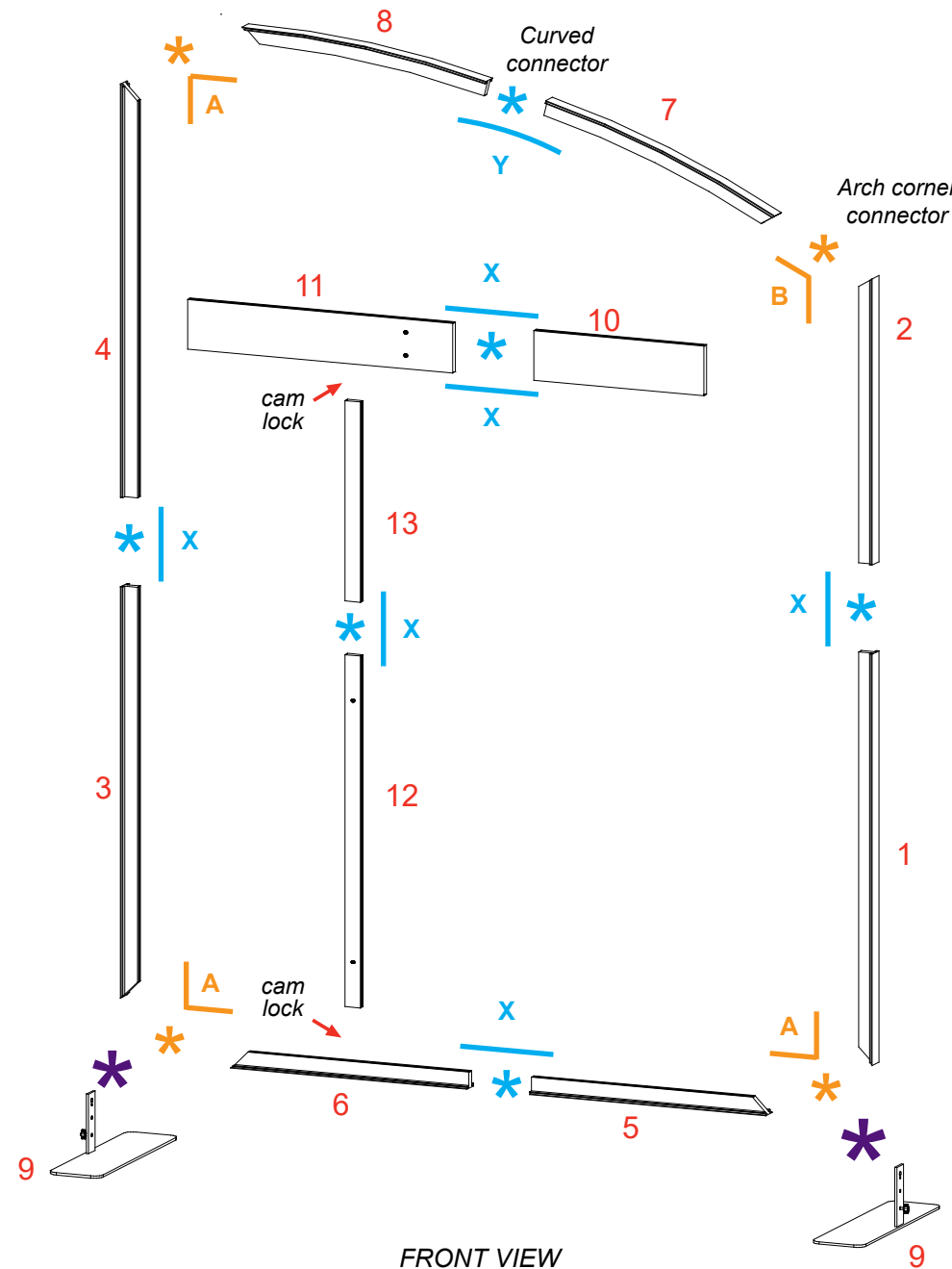

*** Base Plate Attachment**

- 1) Place key hole over bolt on panel & slide down.
- 2) Twist knob to secure connection.

- Steps:
- 1) Apply SEG graphic to side of frame with counter & monitor mount first.
Refer to the SEG Installation general information page.
 - 2) Connect Monitor Mount to horizontal [11]. See **Monitor Mount Attachment** detail.
 - 3) Attach Counter to vertical [12] using standoff barrels & screw caps.
 - 4) Apply SEG graphic to other side of frame assembly.

*** Monitor Mount Attachment**

Attach Monitor Mount to horizontal extrusion using standoff barrels, bolts & wing nuts.

Stand-Off Barrel

Wing nuts

Z140

Monitor Mount Back piece

Bolts

Slide monitor mount into back piece.

Standoff Barrel Attachment

Standoff Barrel

Counter

Cap

Z45

Attach standoff barrels to backwall and secure in place. Secure Counter to standoff barrels using screw caps.

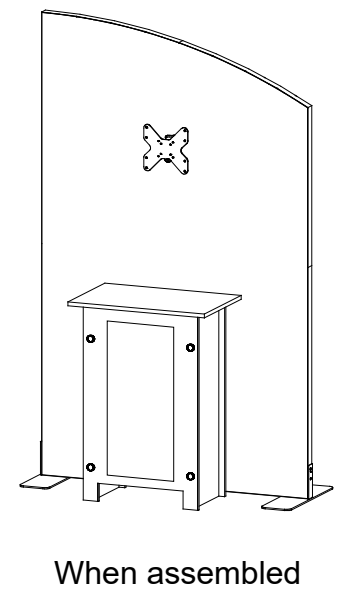
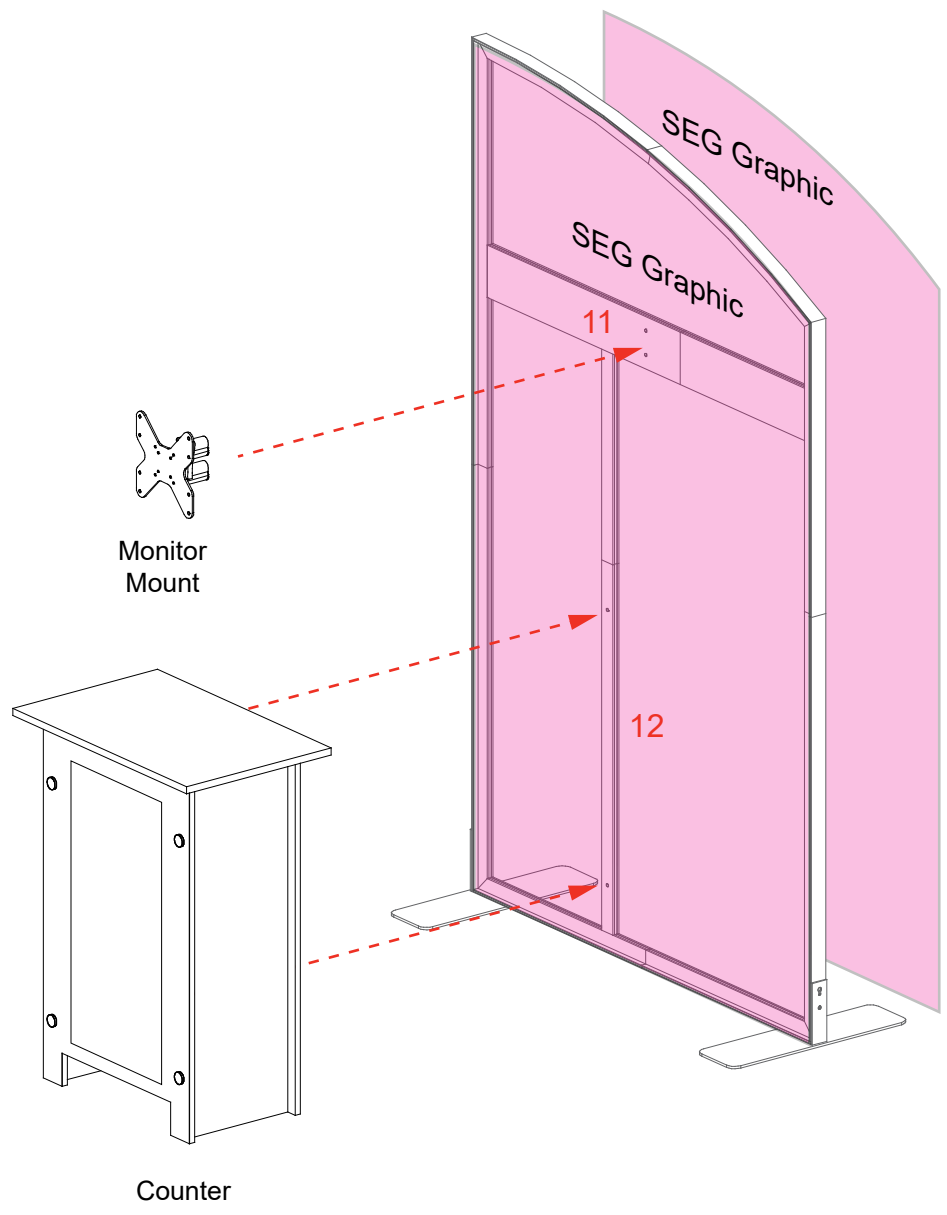

Item	Qty.	Description
1	1	45"h TSP49 Vertical Extrusion
2	1	31.305"h TSP49 Vertical Extrusion
3	1	45"h TSP49 Vertical Extrusion
4	1	45"h TSP49 Vertical Extrusion
5	1	27.35"w TSP49 Horizontal Extrusion
6	1	27.35"w TSP49 Horizontal Extrusion
7	1	28.514"w TSP49 curved Horizontal Extrusion
8	1	28.514"w TSP49 curved Horizontal Extrusion
9	2	6" x 22" End Base Plate w/ foot
10	1	20"w Z140 Horizontal Extrusion
11	1	31.121"w Z140 Horizontal Extrusion
12	1	39"h Z45 Vertical Extrusion
13	1	22.203"h Z45 Vertical Extrusion

Steps:

Refer to the *Tool-less Frame Assembly* general information page.

- 1) Assemble vertical extrusions [1-2], [3-4] & horizontal extrusions [5-6], [7-8] together, using **Tool-less Spline connectors** labeled [X] & [Y].
- 2) Connect vertical assemblies [1/2], [3/4] between horizontal assemblies [5/6], [7/8], using **Tool-less Corner Connectors** labeled [A] & [B].
- 3) Attach horizontals [10-11] between verticals [1/2], [3/4].
- 4) Connect verticals [12-13] between horizontals [5/6] & [10/11].
- 5) Install Base Plates [9] to bottom corners of frame assembly as shown. See **Base Plate Attachment** detail.

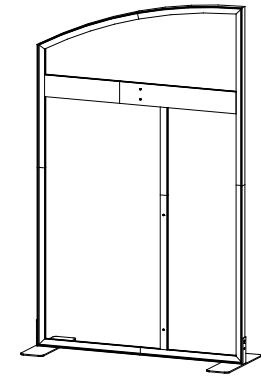

When assembled

Assemble frame flat on ground.

*** Tool-less Spline Connector**

1. Place extrusions end-to-end.
2. Slide tool-less connectors across seam of extrusions.
3. Tighten all knobs to secure connection.

*** Tool-less Corner Connector**

1. Slide extrusion onto Corner Connector.
2. Tighten all knobs to secure connection.

Keep corner connectors attached to horizontal extrusions.

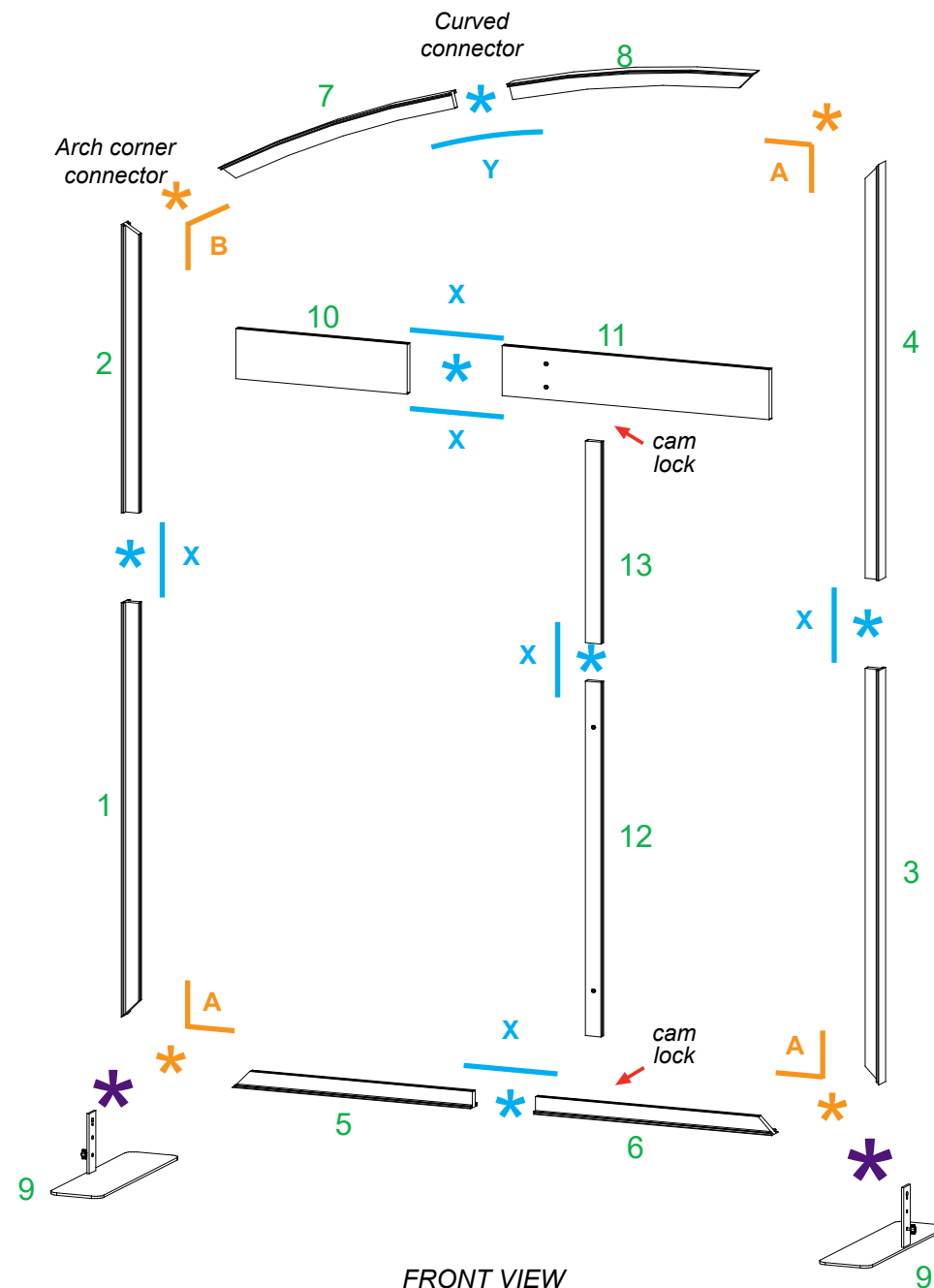

FRONT VIEW

*** Base Plate Attachment**

- 1) Place key hole over bolt on panel & slide down.
- 2) Twist knob to secure connection.

Steps:

- 1) Apply SEG graphic to side of frame with counter & monitor mount first.
Refer to the SEG Installation general information page.
- 2) Connect Monitor Mount to horizontal [11]. See **Monitor Mount Attachment** detail.
- 3) Attach Counter to vertical [12] using standoff barrels & screw caps.
- 4) Apply SEG graphic to other side of frame assembly.

*** Monitor Mount Attachment**

Attach Monitor Mount to horizontal extrusion using standoff barrels, bolts & wing nuts.

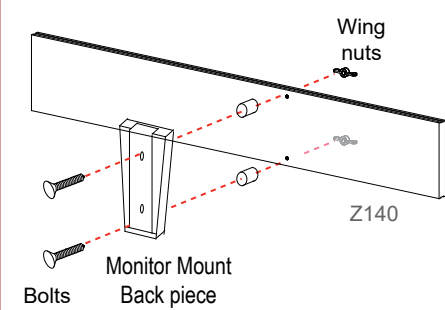
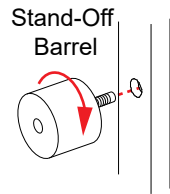

Slide monitor mount into back piece.

Standoff Barrel Attachment

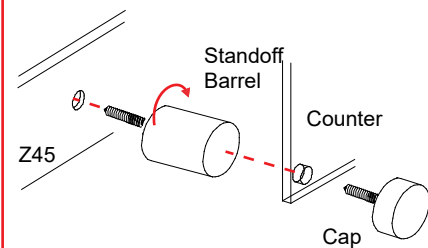

Attach standoff barrels to backwall and secure in place. Secure Counter to standoff barrels using screw caps.

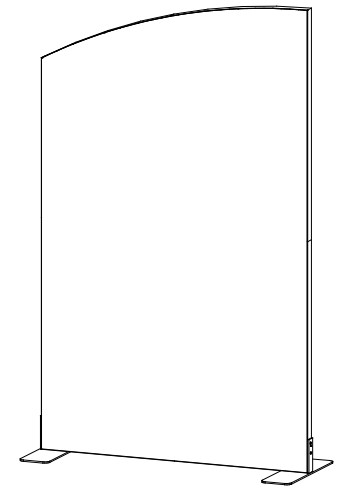
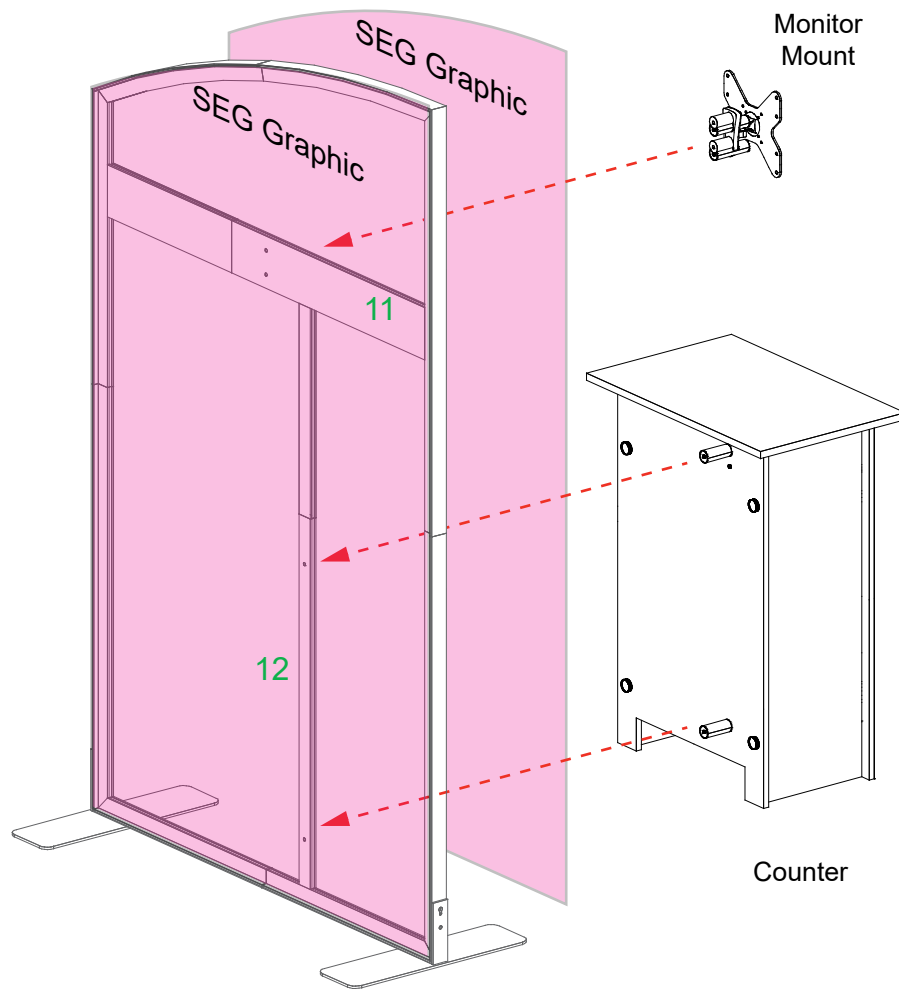

When assembled

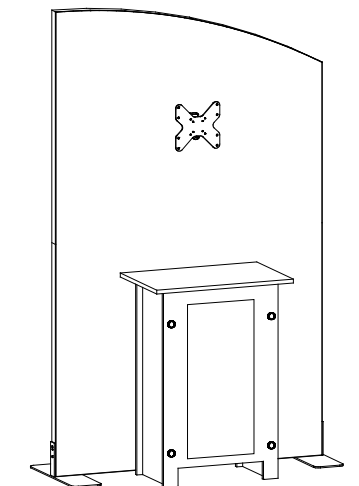

BACK VIEW

Item	Qty.	Description
22	1	41.040"h CEI152 Vertical Extrusion
23	1	41.040"h CEI152 Vertical Extrusion
24	1	42"w CEI152 Horizontal Extrusion
25	1	42"w CEI152 Horizontal Extrusion

Steps:

- 1) Attach U-Channel to lower horizontal [24]. See [U-Channel Attachment](#) detail.
- 2) Assemble verticals [22,23] between horizontals [24,25] using corner connectors. Refer to the [CEI152 Frame Assembly general information page](#).
- 3) Attach lower horizontal [24] to Base using threaded pins & wing nuts. See [Pin & Wing Nut Connection](#) detail.
- 4) Attach upper horizontal [25] to Counter Top using threaded pins & wing nuts. See [Pin & Wing Nut Connection](#) detail.
- 5) Connect power cords to Supernova lights as shown.
- 6) Apply SEG graphics to front & back of lightbox. Refer to the [SEG Installation general information page](#).

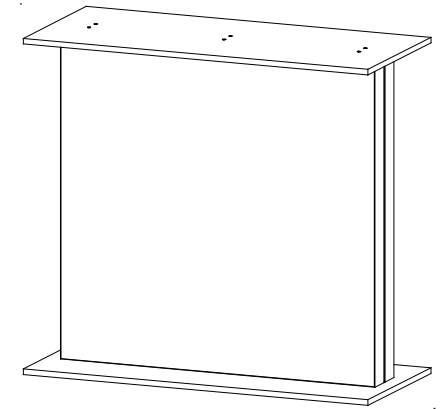

When assembled

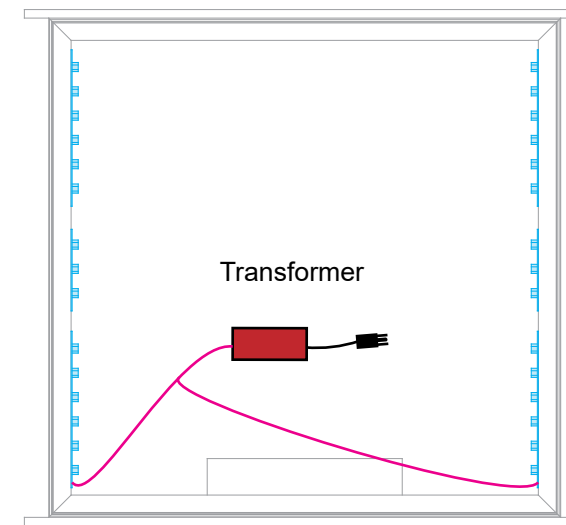
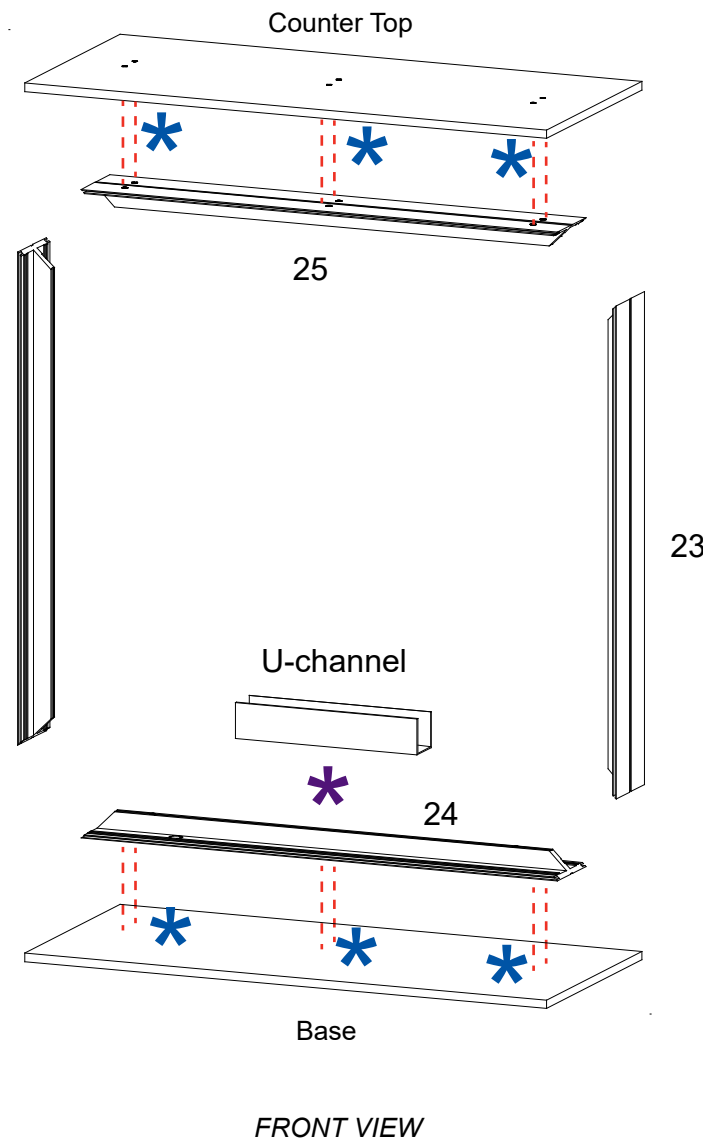
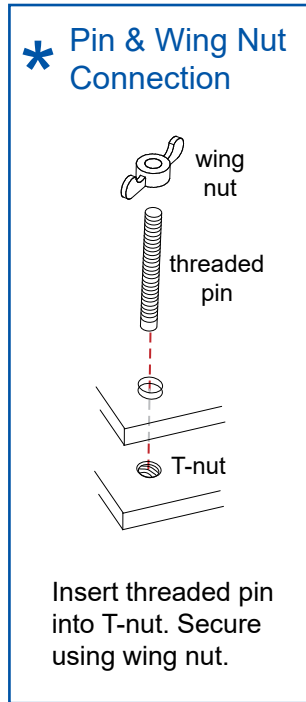

FRONT ELEVATION VIEW

