

Plan View

10'

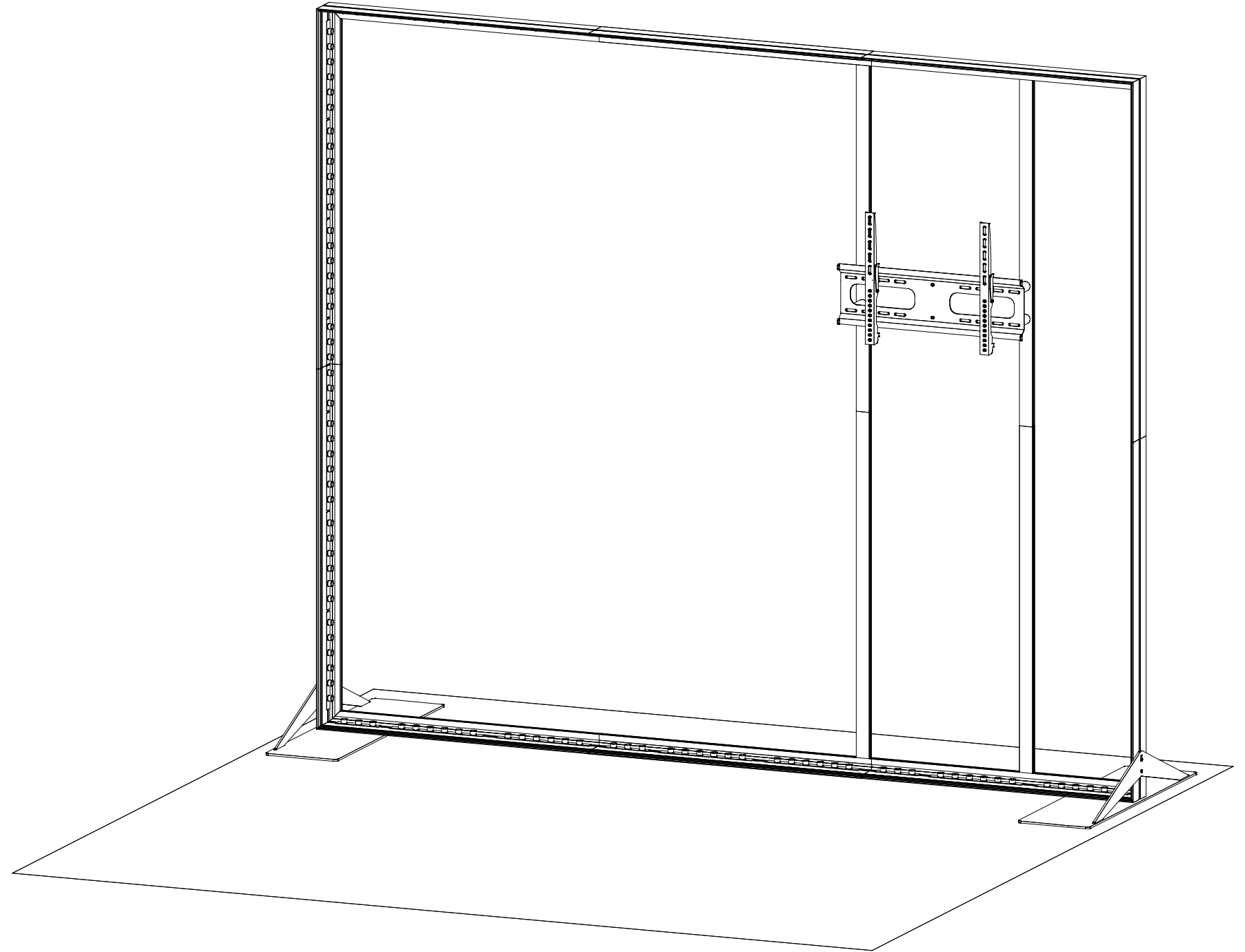

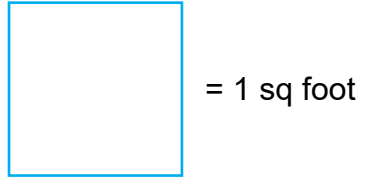
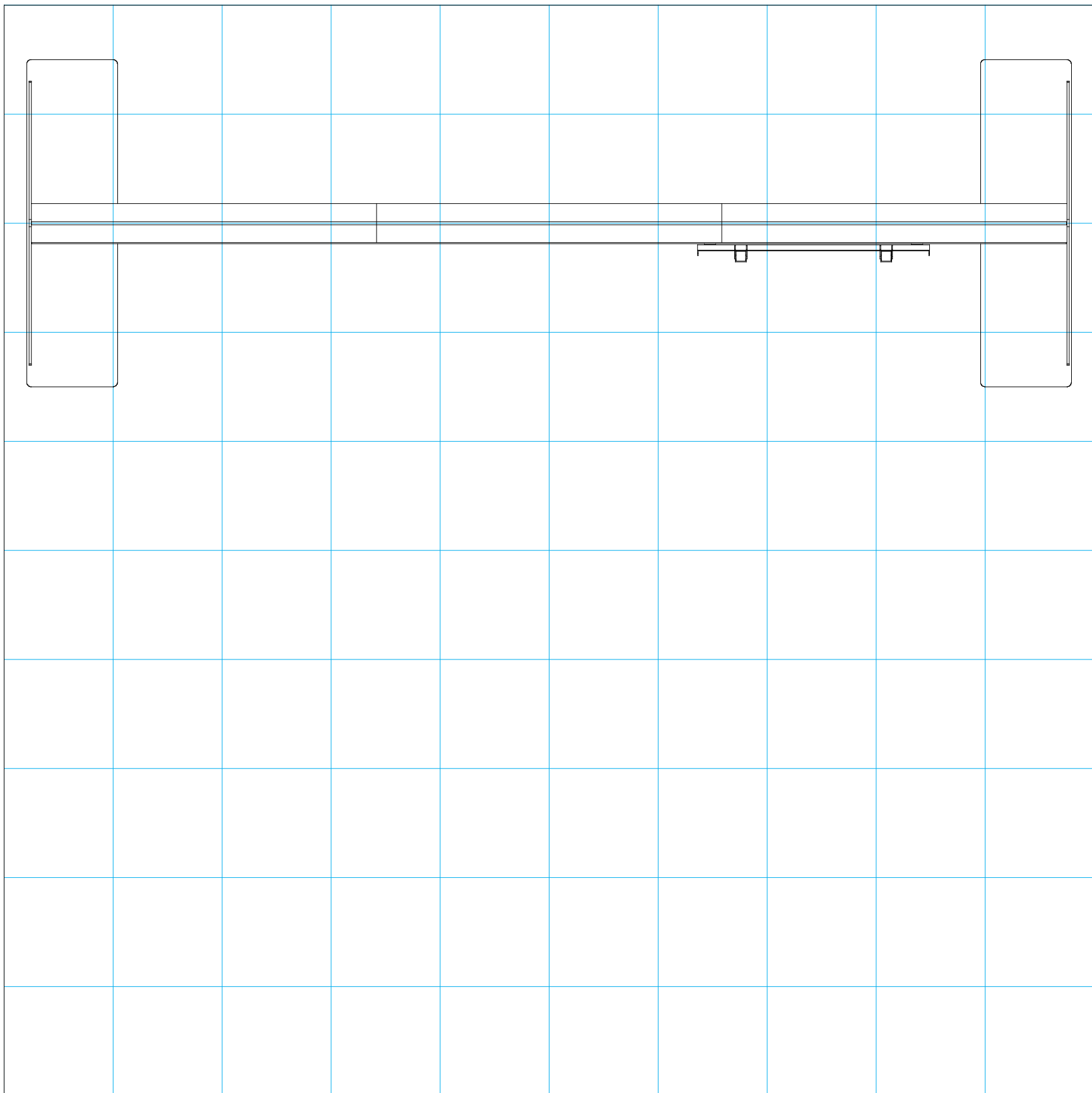

## General Setup Instructions

- Read entire setup instruction manual prior to unpacking parts and pieces.
- The setup instructions are created specifically for this configuration.
- Setup instructions are laid out sequentially in steps, including exploded views with detailed explanation for assembly.

## Cleaning & Packing

- For Cleaning Metal, Plex, & Laminate Parts: Use a **MILD NON-ABRASIVE** cleanser and soft cloth/paper towel to clean all surfaces.
- Keep exhibit components away from heat and prolonged sun exposure. **Heat and UV exposure will warp and fade components.**
- Retain all provided Packing Materials. All provided packing materials are for ease of repacking & component protection.

## Disassembly

- For loss prevention, tighten all set screws and locks during disassembly.

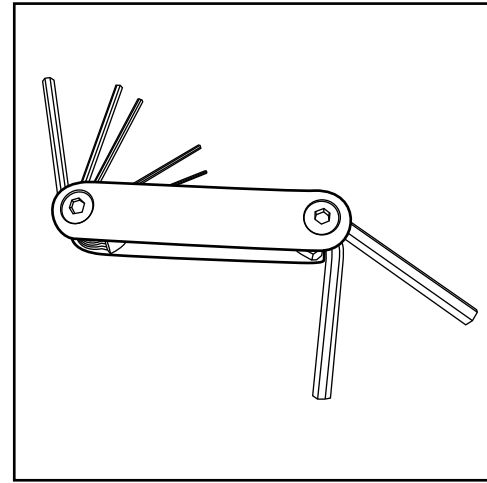

Hex Tool - Essential for Assembly

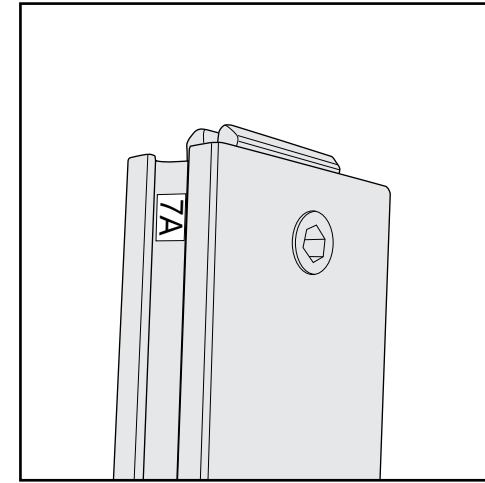

Part Identification - Numbering

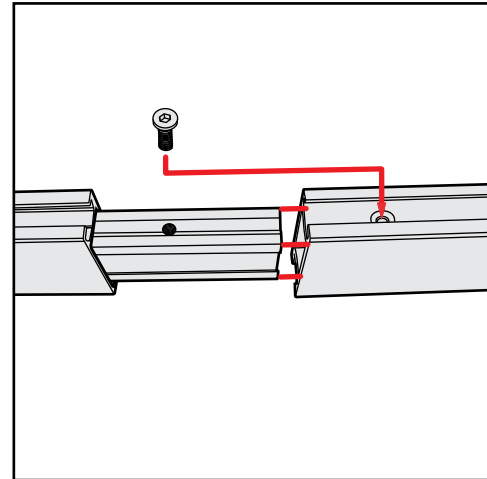

Spline Connection

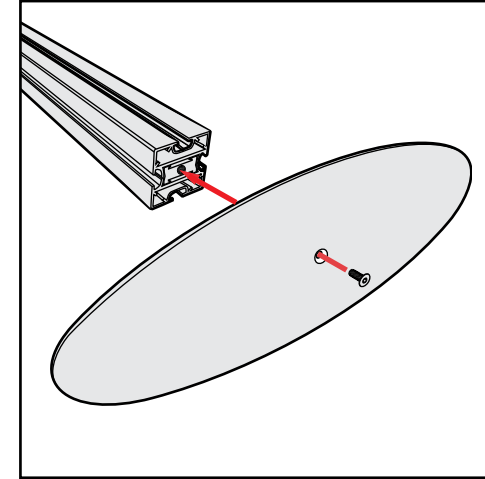

Base Plate & Extrusion Connection

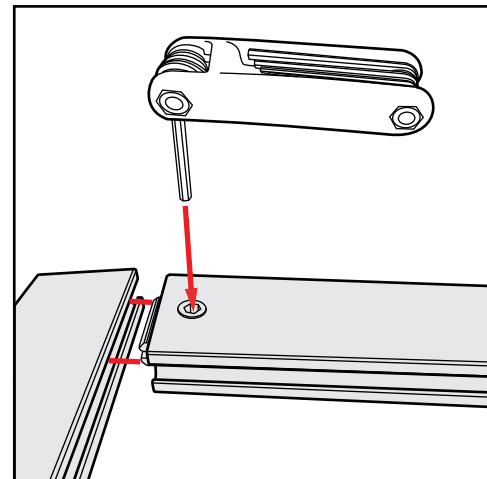

Extrusion & Lock Connection

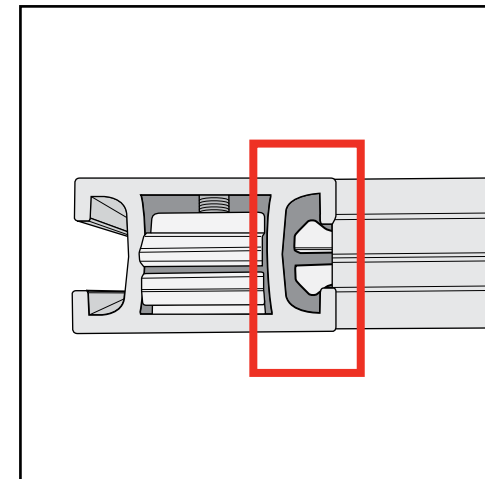

Engaged Lock



# WARNING



DO NOT USE POWER TOOLS

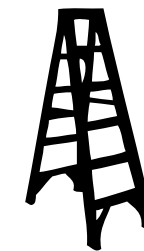

LADDERS OR LIFTS  
MAY BE REQUIRED



ALL CONNECTIONS MUST  
BE TIGHTLY SECURED

## Straight Connection

When assembling frame, first attach all **straight connectors**, then attach **corner connectors**.

- 1) Place extrusions end-to-end.
- 2) Loosen all knobs, then slide **straight connectors** across the seam of extrusions.
- 3) Tighten all knobs to secure connection.

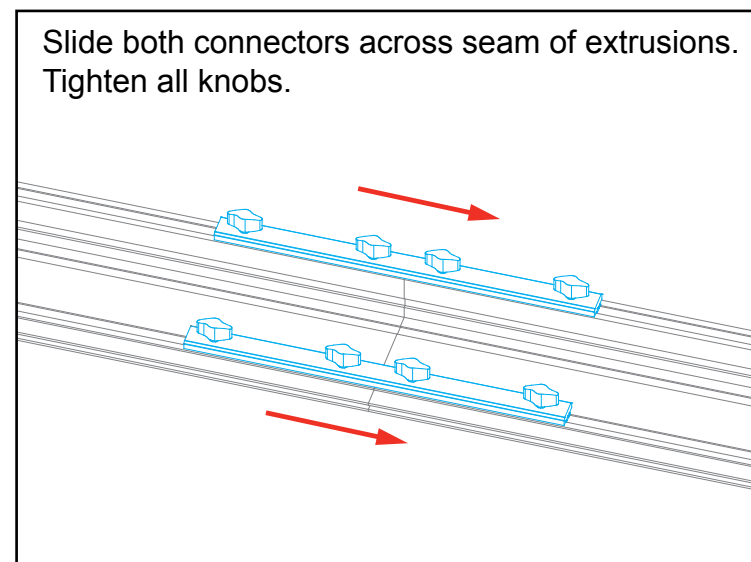
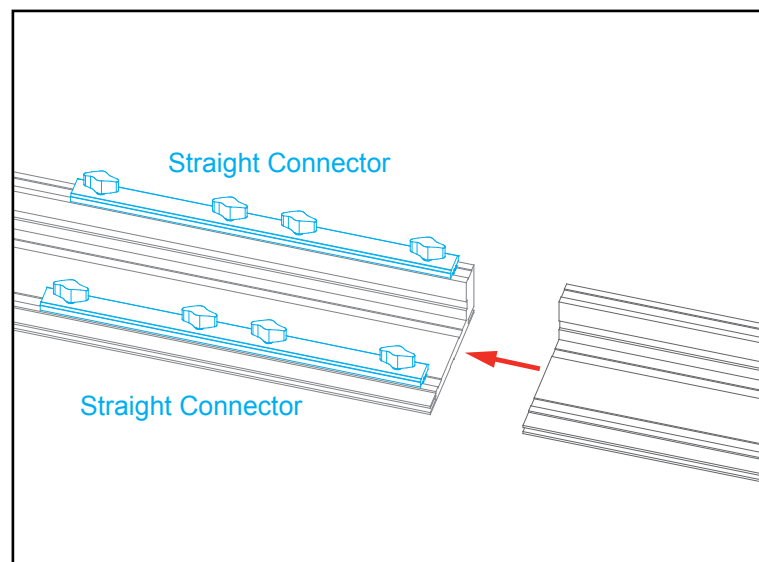

All knobs must be tightened securely to ensure a proper connection.

## Disassembly

- 1) Loosen all knobs.
- 2) Slide connectors off of one extrusion.
- 3) Tighten knobs to prevent loss during packing & shipping.

Keep straight connectors in groove of extrusion. Do not remove connectors during disassembly.

## Corner Connection

- 1) Loosen knobs, then slide vertical extrusions onto **corner connectors** of **lower** horizontal extrusion.
- 2) Slide **corner connectors** of **upper** horizontal extrusion into grooves of vertical extrusions.
- 3) Tighten all knobs to secure connection.

## Disassembly

- 1) Loosen knobs on vertical extrusions.
- 2) Slide the vertical extrusions off of **corner connectors** on lower and upper horizontal extrusions.

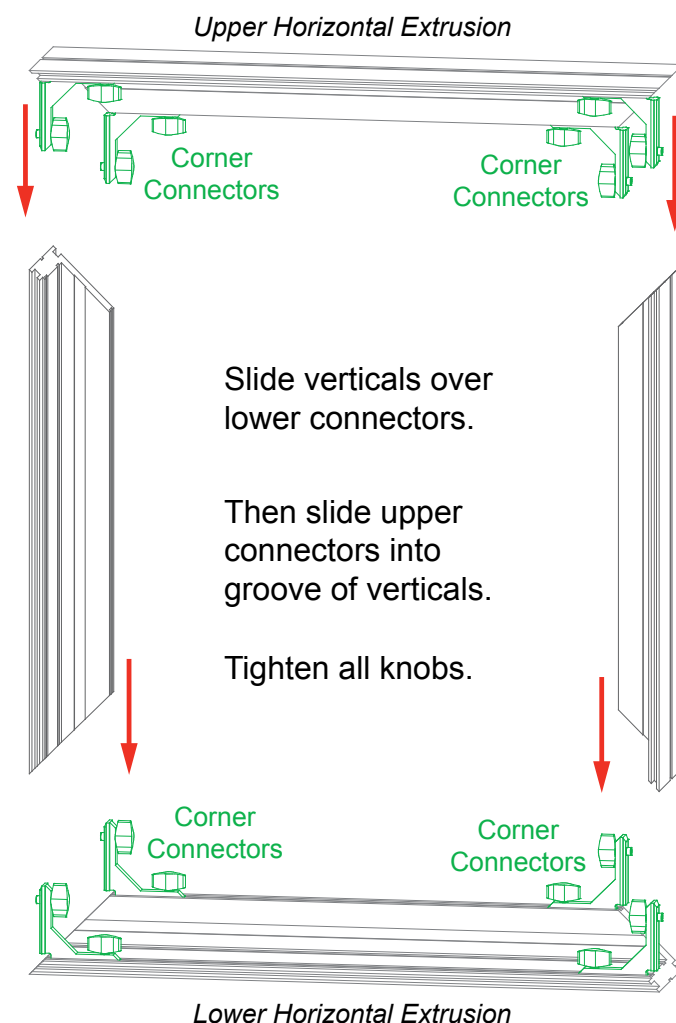

Adjust connectors if necessary to prevent gaps in connection.

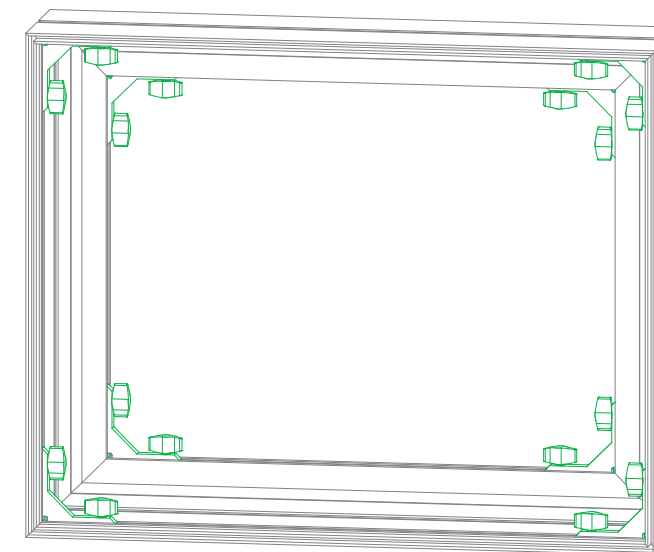

COMPLETED ASSEMBLY

All knobs must be tightened securely to ensure a proper connection.

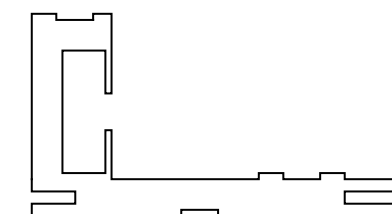

CEI110 Profile

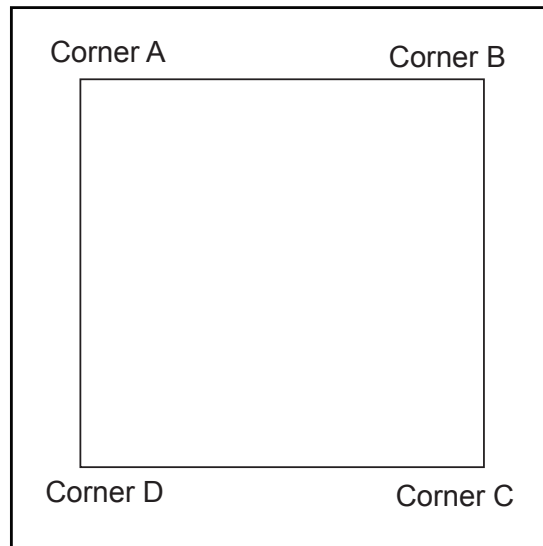

It is important to first insert graphic into each alternate corner then to the sides of the frame. If this is not done, graphic will not fit into the frame correctly.

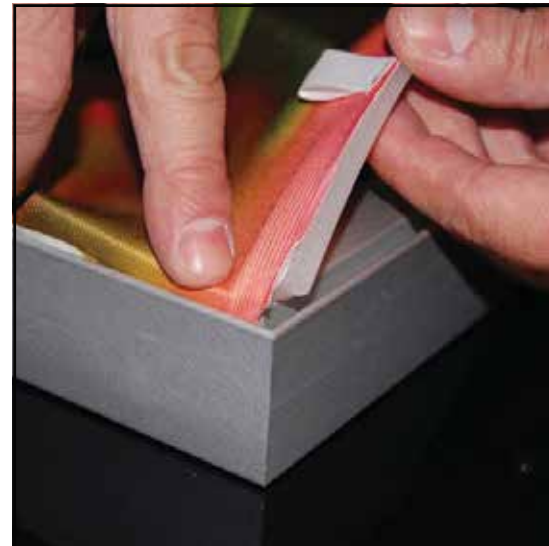

**Step 1**  
Insert corner A. Turn edge of graphic so silicon welt is perpendicular to face of graphic. Insert narrow side of welt with fabric to outside into the channel. Repeat for other side of this corner.



**Step 2**  
Repeat Step 1 for opposite corner C, then insert corner B, followed by corner D, to complete the installation of the corners.

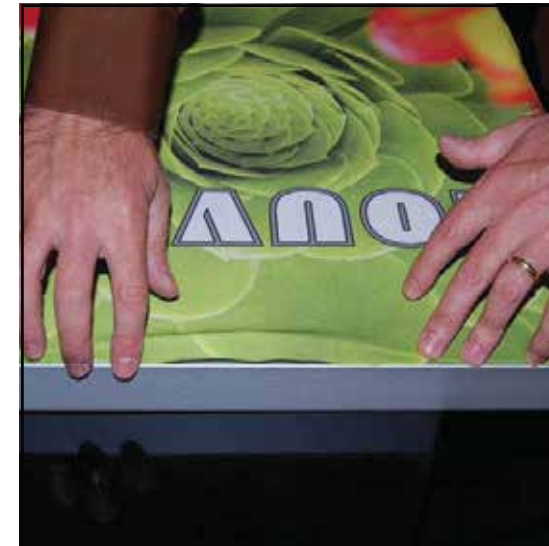

**Step 3**  
Once all corners are inserted, press one silicon edge into channel from corners and work toward the center. Make sure welt is fully inserted into channel. Continue until all sides are done. Smooth out edges of graphic.

### Graphic Removal

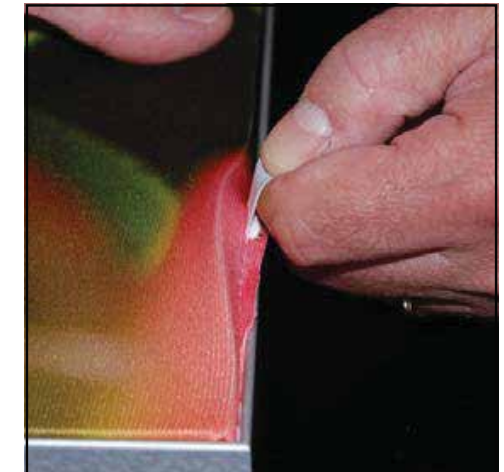

To remove the graphic from the frame, locate the fabric pull tab. Gently pull up on the tab to remove the fabric.

### Top View of Each Level

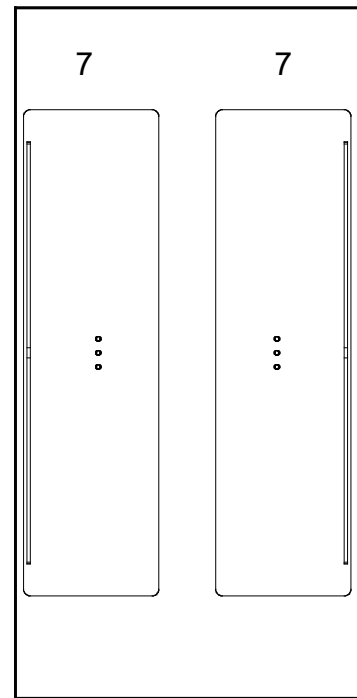

Level 1  
(Bottom level)

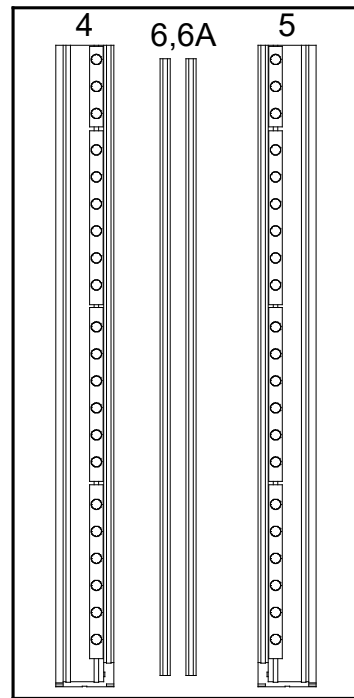

Level 2

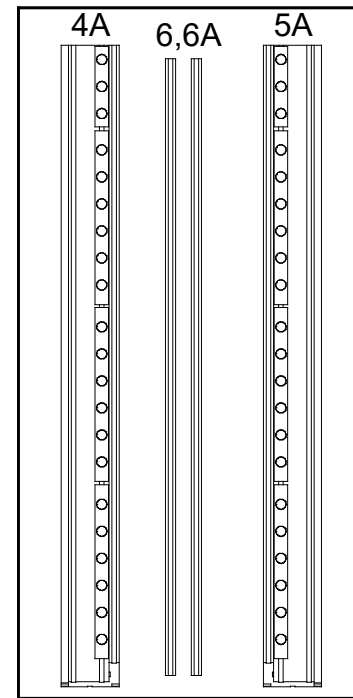

Level 3

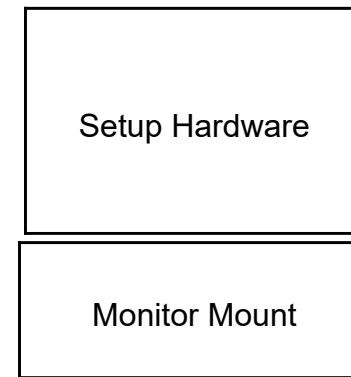

### Top View of Each Level

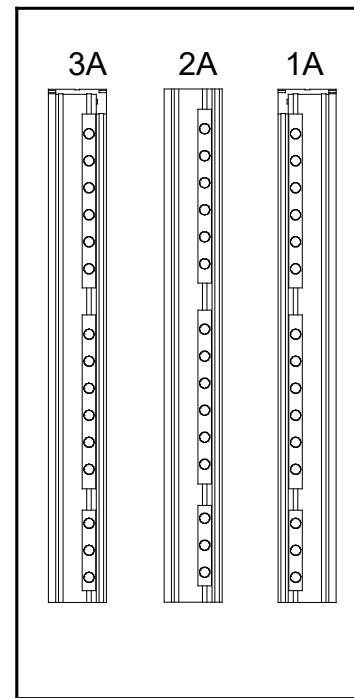

Level 1  
*(Bottom level)*

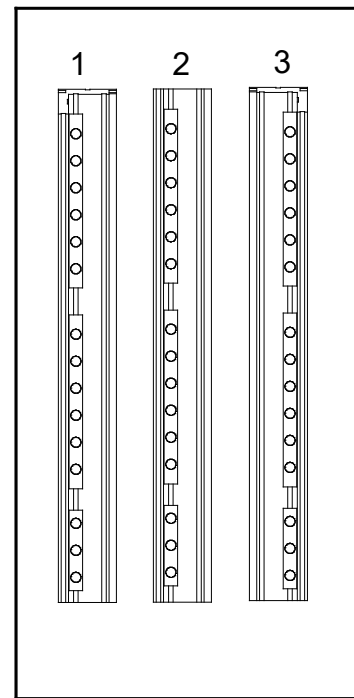

Level 2

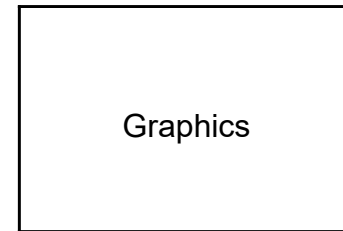

Item	Qty.	Description
1,1A	1,1	38" CEI110 Horizontal Extrusion
2,2A	1,1	38" CEI110 Horizontal Extrusion
3,3A	1,1	38" CEI110 Horizontal Extrusion
4,4A	1,1	47.5" CEI110 Vertical Extrusion
5,5A	1,1	47.5" CEI110 Vertical Extrusion
6,6A	2,2	45.677" Z45 Vertical Extrusion
7	2	Base Plate

Assemble frame flat on ground.

Steps:

Refer to the CEI110 Frame Assembly general information page.

- 1) Assemble horizontals [1-2-3], [1A-2A-3A] & verticals [4-5], [4A-5A] using tool-less spline connectors.
- 2) Connect vertical assemblies [1/2/3], [1A/2A/3A] between horizontals [4/5], [4A/5A] using tool-less corner connectors.
- 3) Attach verticals [6-6A] between horizontal assemblies [1/2/3], [1A/2A/3A]. See **Z45 Attachment** detail.
- 4) Connect Base Plates [7] to assembled frame. See **Base Plate Attachment** detail.

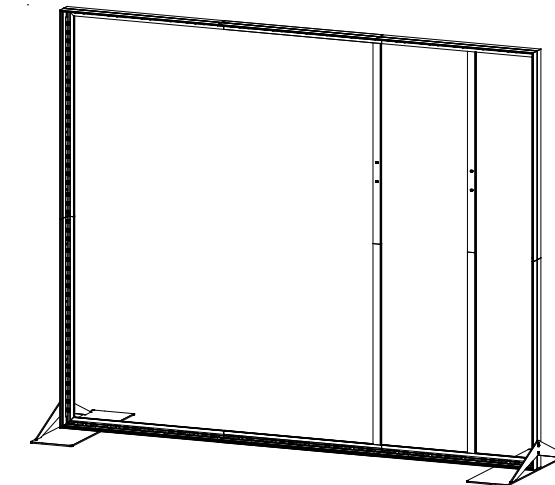

When assembled

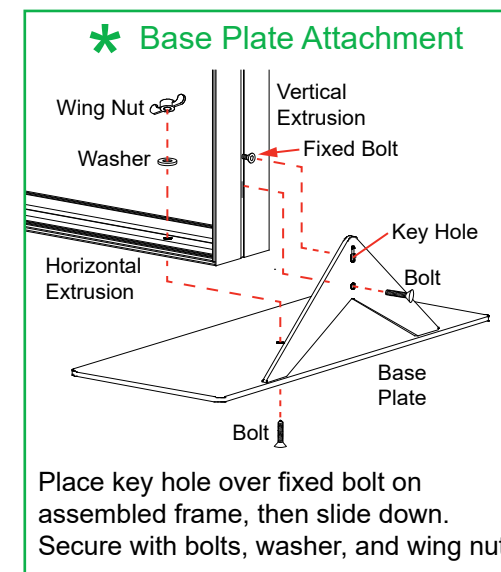
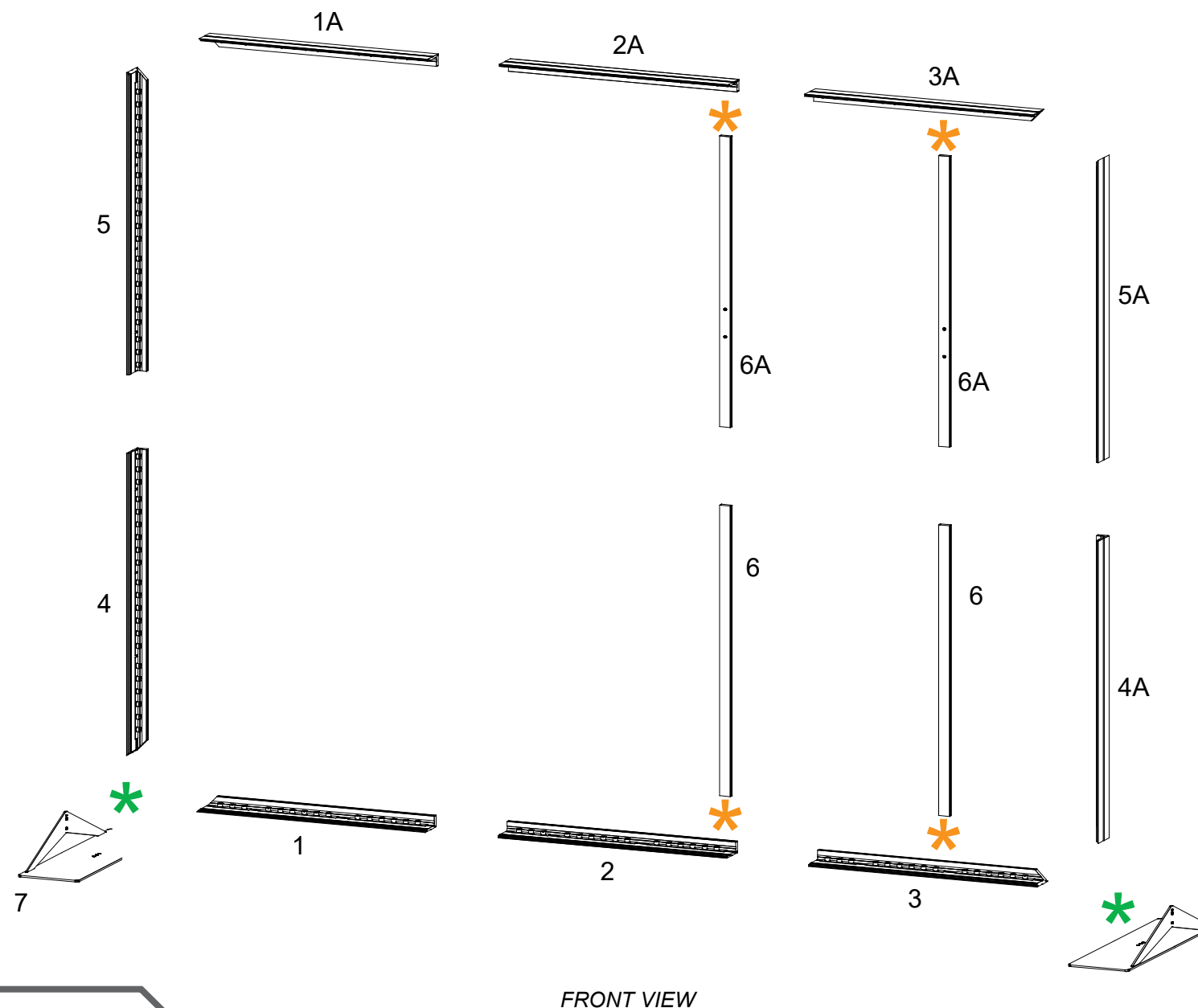
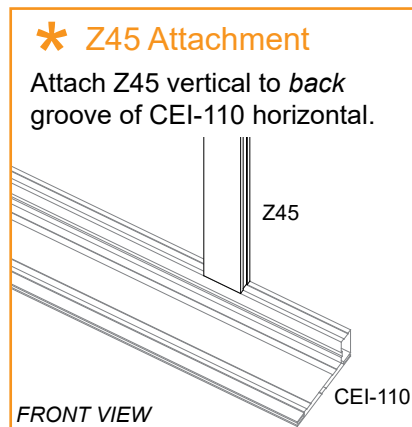



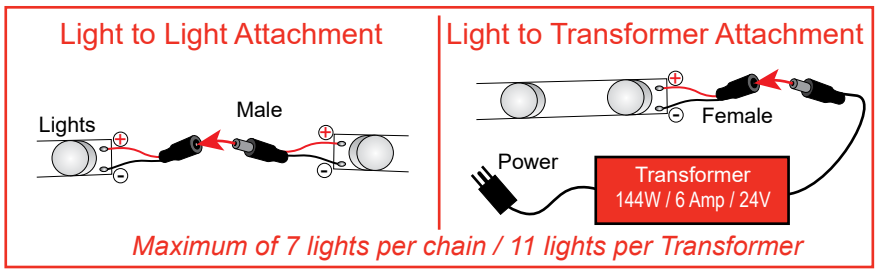

Steps:  
1) Connect power cords to Supernova lights, as shown.

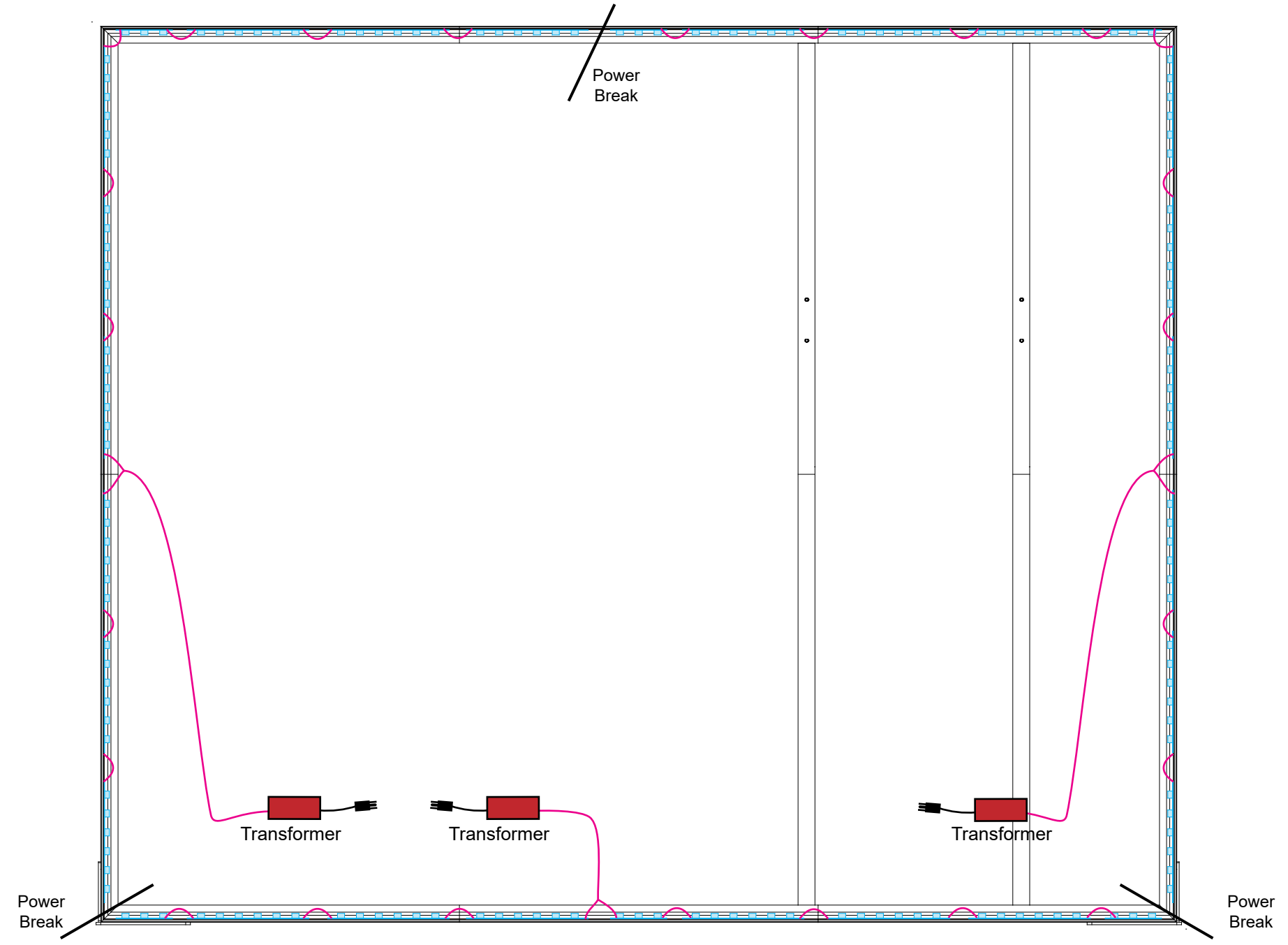

ELEVATION VIEW

Item	Qty.	Description
--	4	Standoff Barrel
--	1	Large Monitor Mount

Steps:

Refer to the SEG Installation general information page.

- 1) Apply SEG Graphic to front of assembled frame.
- 2) Install Monitor Mount to verticals [6/6A] using standoff barrels.  
See [Monitor Mount Attachment](#) detail.
- 3) Apply SEG Blocker to back of assembled frame.

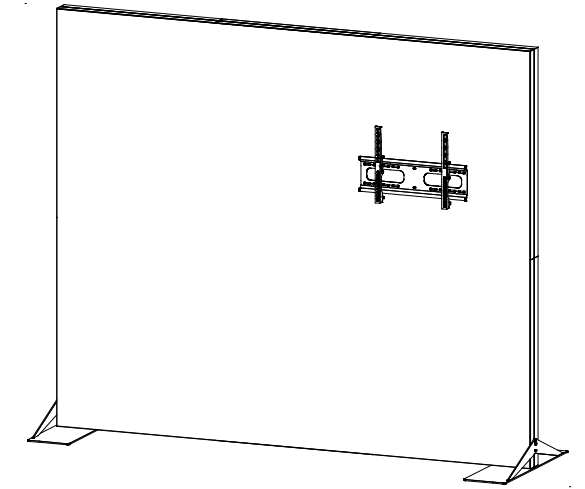

When assembled

**\* Monitor Mount Attachment**

The diagram shows a monitor mount being attached to a vertical extrusion. A standoff barrel is inserted into the extrusion, and the monitor mount is secured to it with a cap. The entire assembly is shown in relation to an SEG Graphic panel.

Screw standoffs into vertical extrusions. Attach monitor mount to standoffs, using caps

**Standoffs attach through SEG graphic.**

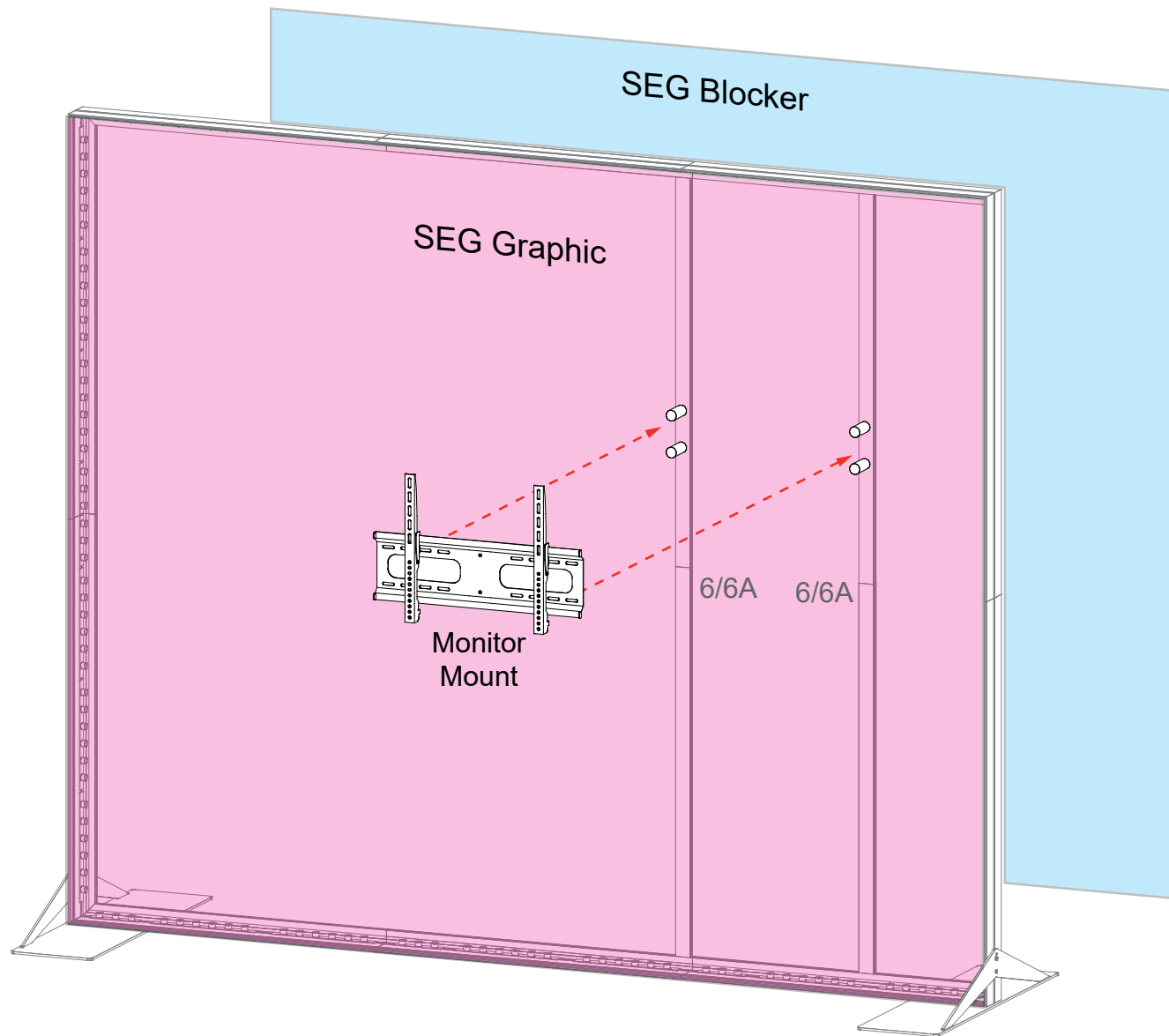

FRONT VIEW