

Top View

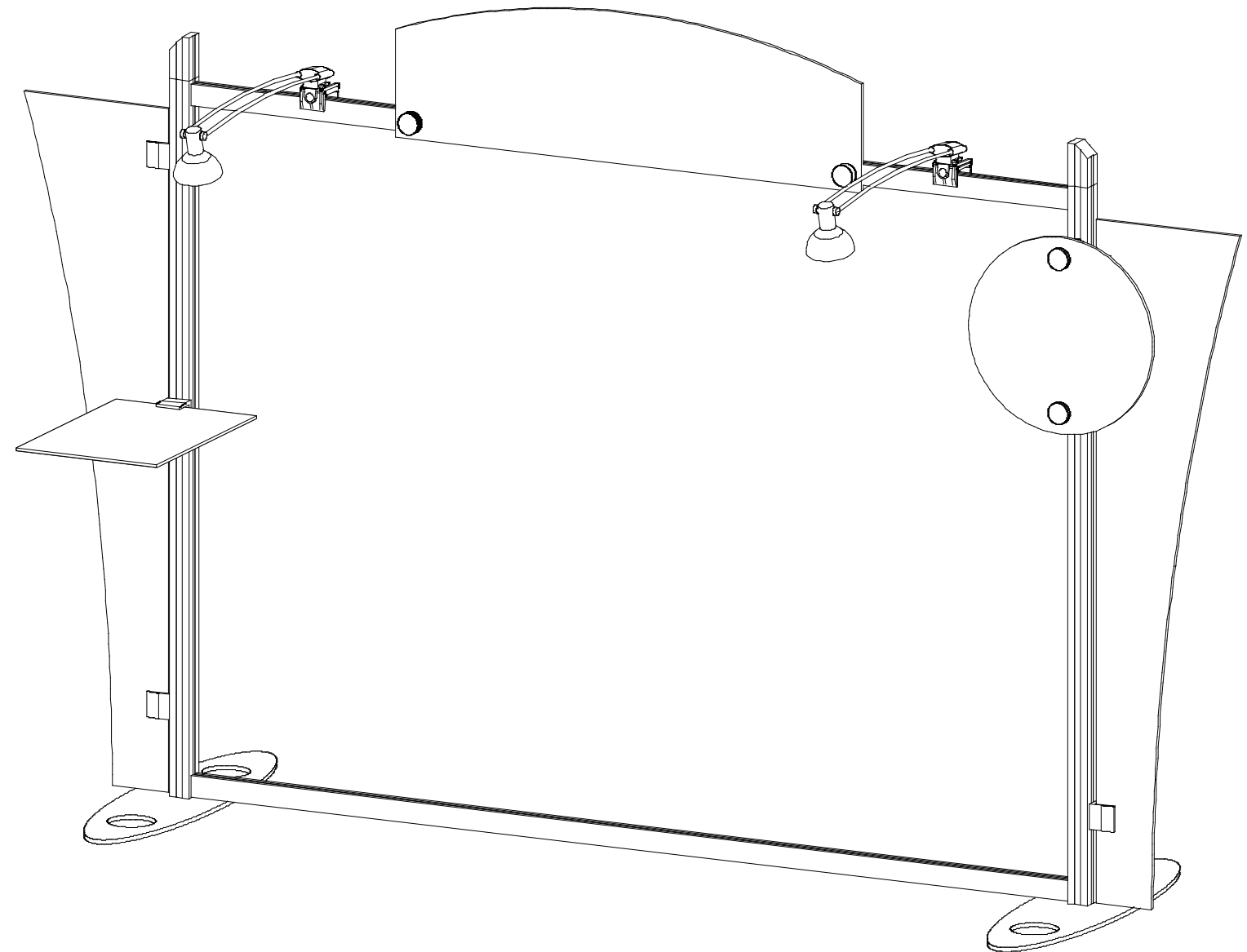

SETUP INSTRUCTIONS

General Setup Instructions

- Read entire setup instruction manual prior to unpacking parts and pieces.
- The setup instructions are created specifically for this configuration.
- Setup instructions are laid out sequentially in steps, including exploded views with detailed explanation for assembly.

Cleaning & Packing

- For Cleaning Metal, Plex, & Laminate Parts: Use a **MILD NON-ABRASIVE** cleanser and soft cloth/paper towel to clean all surfaces.
- Keep exhibit components away from heat and prolonged sun exposure. **Heat and UV exposure will warp and fade components.**
- Retain all provided Packing Materials. All provided packing materials are for ease of repacking & component protection.

Disassembly

- For loss prevention, tighten all set screws and locks during disassembly.

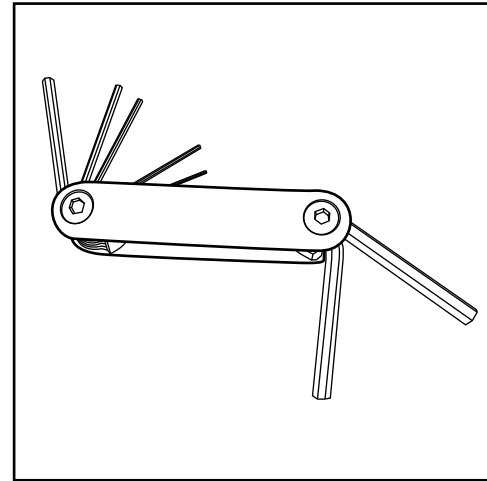

Hex Tool - Essential for Assembly

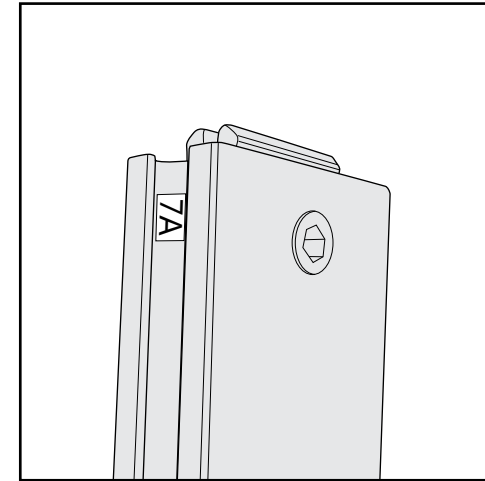

Part Identification - Numbering

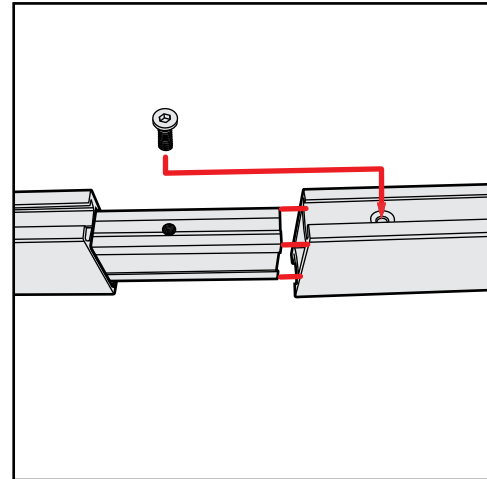

Spline Connection

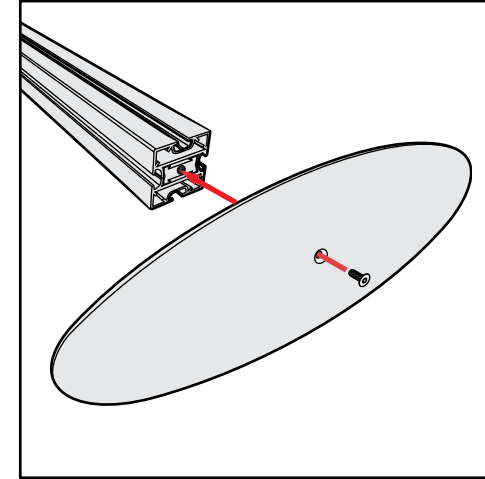

Base Plate & Extrusion Connection

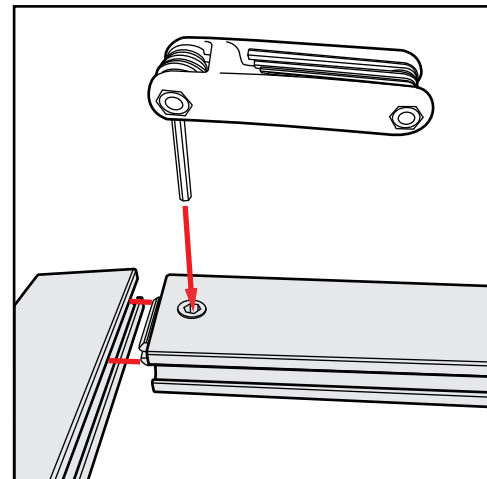

Extrusion & Lock Connection

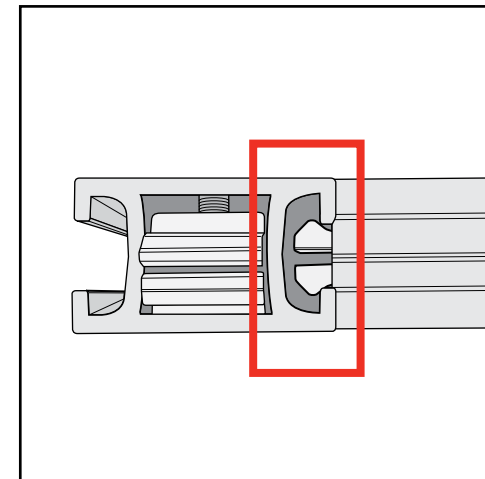

Engaged Lock



WARNING

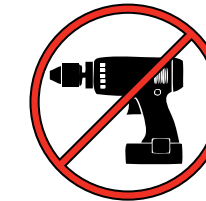

DO NOT USE POWER TOOLS

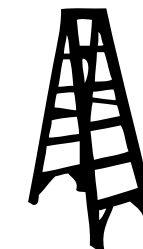

LADDERS OR LIFTS
MAY BE REQUIRED



ALL CONNECTIONS MUST
BE TIGHTLY SECURED

Top View of Each Level

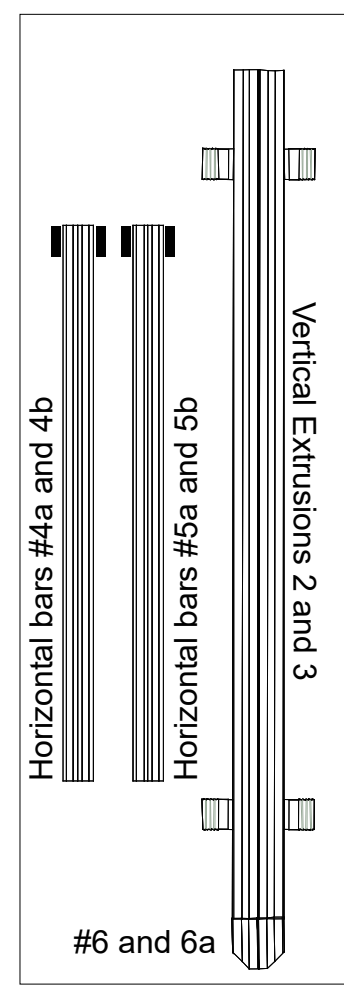
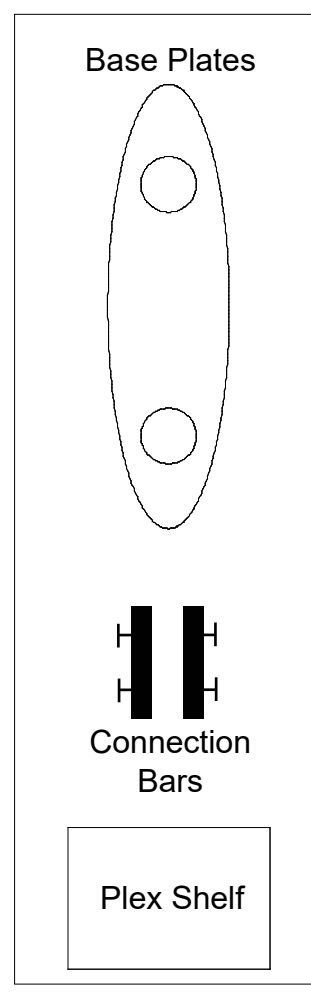
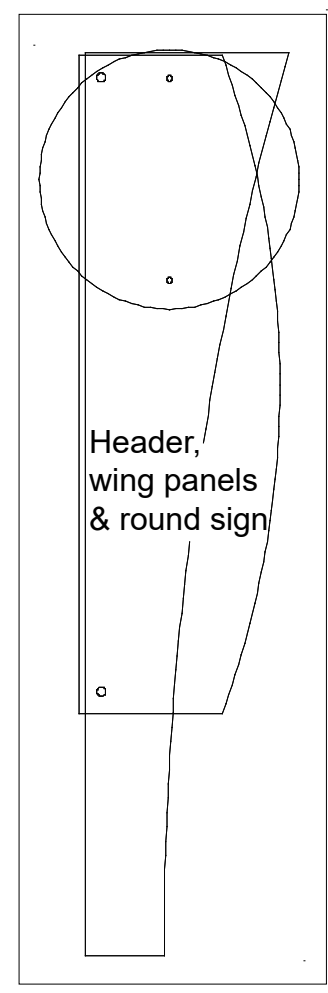

Graphics

Lights
and
Setup Hardware

Item	Qty	Description
1	2	Base Plate
2	1	42" Square Vertical Extrusion
3	1	42" Square Vertical Extrusion
4a/4b	1/1	27.5" Horizontal Extrusion
5a/5b	1/1	27.5" Horizontal Extrusion
6/6a	1/1	2.5" Angle-Cut Vertical

- Steps:
1. Attach vertical extrusions [2 and 3] to base plates [1].
 2. Connect horizontal extrusions [4a to 4b and 5a to 5b] together using connection bars.
 3. Attach horizontal assemblies [4a/4b and 5a/5b] between vertical extrusions as shown.
 4. Attach angle-cut verticals to top of assembled backwall where indicated.
 5. Apply graphic to back of assembled backwall.

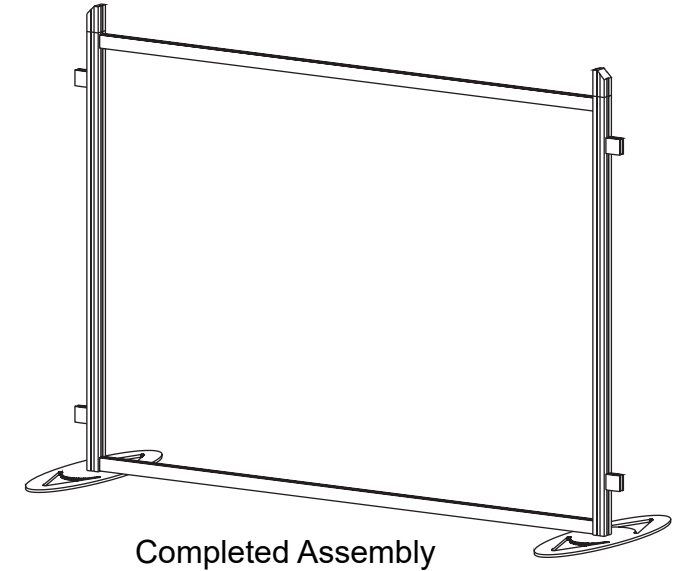

A10 Clamp Attachment

Slide connector on back of A10 clamp into groove of extrusion.

When desired location is found, tighten set screw to secure.

Tighten knob to secure shelf in place.

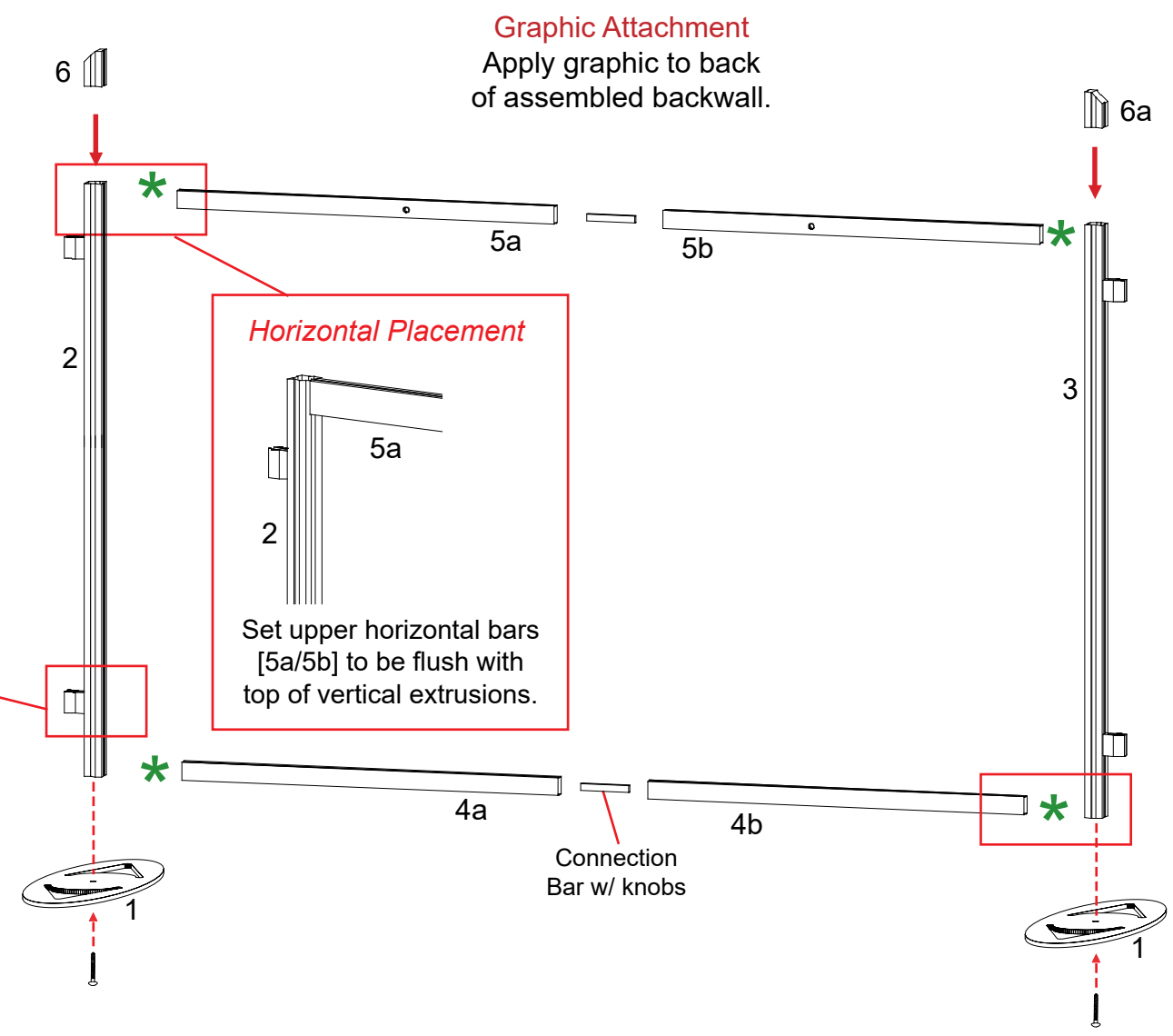

2.5" Vertical Attachment

Tighten setscrew to secure

Insert connect into groove of extrusion [3]. Tighten setscrew to secure.

Back View of Unit

GREEN STAR indicates location of connection lock with knob.

Steps:

- 1) Attach Header to upper Horizontals, using Screw Caps.
- 2) Attach Wing Panels and Shelf to A10 clamps.
- 3) Attach Sign to Vertical Extrusion [3]. See [Sign Attachment](#) detail.
- 4) Connect Lights to top Horizontals, where desired. See [Light Connection](#) detail.

